



www.fine-tek.com

小型浮球液位開關



產品簡介

隨著科技進步，各種產品的設備要求更安全、更方便，價格更低廉。小型浮球開關是一種結構簡單，使用安裝方便的液位控制器。它沒有複雜的電路，不會受到干擾。只要材質選用正確，在任何環境下的液體、壓力或是溫度皆可使用。

液體性質與浮球關係

◎如下圖，液體比重不同時，浮球的動作位置將會有所變動。當液體比重比水小時，浮球浸在液體中的部份會相對增多。

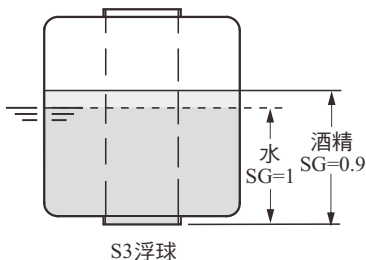

本公司產品以水(SG=1)為參考比重。所以使用者在選用浮球時必須考慮液體比重一定要大於浮球規格上所標示之值，否則，浮球無法浮動，磁簧開關就無法動作。

◎粘度高不會乾涸液體，一般可選用外徑較大的浮球；因為當液位上升時，浮球有較大浮力可以克服液體表面張力，而當液位下降時，因為浮球比較重，所以可避免被粘著。

◎浮球開關是使用磁鐵來感應磁簧開關，因此被測液體中若有鐵屑，一定要將鐵屑先行濾清，才不會影響浮球液位開關的正確動作。

動作原理

1)水平安裝"H"型内部的磁簧開關與磁鐵的相關位置如下圖。當磁鐵靠近磁簧開關時，磁簧開關接點ON，磁鐵離開磁簧開關時，開關則由ON變為OFF

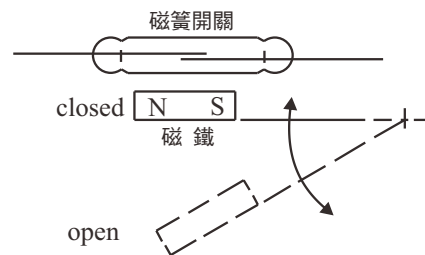

2)垂直安裝"V"型内部的磁簧開關與磁鐵的相關位置如下圖。當環狀磁鐵靠近磁簧開關中心時，磁簧開關接點ON，磁鐵離開磁簧開關中心時，磁簧開關會由ON變為OFF

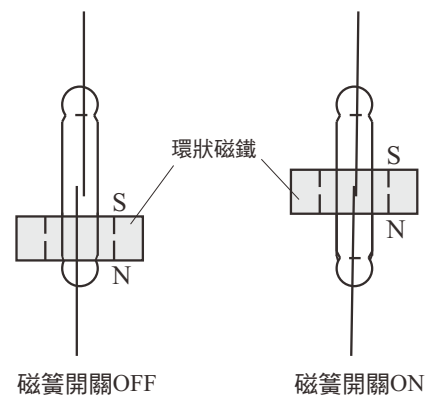

化學特性

● 優 ○ 好 △ 普通 × 劣

化學式	濃度 %	溫度		塑膠				橡膠	不銹鋼	
		°C	°F	PVC	PP	PVDF	PTFE	NBR	304	316
氨水 NH ₄ OH	10	40	104	●	●	●	●	○		
	10	80	176		○	●	●			
王水 3HCl+HNO ₃	10	40	104	△	△	●	●			
	10	80	176			●	●			
苯 C ₆ H ₆	純	40	104	×	△	○	●			
		80	176			△	●			
漂白液 Ca(ClO) ₂	5	40	104	●		●	●			
	5	80	176			●	●			
	20	40	104	●		●	●			
	20	80	176			●	●			
硼酸 H ₃ BO ₃	飽合	40	104	●	●	●	●	●		
		80	176		●	●	●	○		
鹽水		40	104	●	●	●	●	●		
		80	176		●	●	●			
丁二烯 CH ₂ =CH=CH=CH ₂	氣體	40	104	●		●	●			
		80	176			●	●			
丁烷 CH ₃ (CH ₂) ₂ CH ₃	氣體	40	104	●	●	●	●			
		80	176		●	●	●			
硝酸 HNO ₃	10	40	104	●	●	●	●	●	●	●
	10	80	176	×	○	●	●		●	●
	30	40	104	●	●	●	●		●	●
	30	80	176	×	○	●	●		●	●
	50	40	104	○	○	●	●		●	●
	50	80	176	×	×	○	●			
	70	40	104	○	×	●	●		○	●
	70	80	176	×		○	●			
	98	40	104			○	○			
	98	80	176				△			
草酸 HOOC-COOH	20	40	104	●	●	●	●	●		△
	20	80	176		●	●	●			
	50	40	104	●	●	●	●			△
	50	80	176		●	●	●			
磷酸 H ₃ PO ₄	10	40	104	●	●	●	●	●	●	●
	10	80	176		○	●	●	△	●	●
	50	40	104	●	●	●	●	●	●	●
	50	80	176		△	●	●	×	●	●
	80	40	104	●	●	●	●	○	●	●
	80	80	176		△	●	●		●	●
苛性鈉 NaOH	15	40	104	●	●	●	●	●	●	●
	15	80	176		○	△	●	△	×	×
	30	40	104	●	●	●	●	●	●	●
	30	80	176		○	△	●	●	×	×
	50	40	104	●	●	○	●	●	●	●
	50	80	176		○	×	●	●	×	×
70	40	104	○	○	○	●				
70	80	176		○	×	●				

化學式	濃度 %	溫度		塑膠				橡膠	不銹鋼		
		°C	°F	PVC	PP	PVDF	PTFE	NBR	304	316	
次氯酸鹽 NaClO	3	40	104	●	○	●	●		△	○	
	3	80	176								
	5	40	104	●	○	●	●		△	○	
	5	80	176								
	7	40	104	●	△	○	●		×	×	
	7	80	176								
	10	40	104	●	△	●	●		×	×	
10	80	176									
13	40	104	●	△	●	●		×	×		
13	80	176									
硫酸 H ₂ SO ₄	10	40	104	●	●	●	●	●	●	●	
	10	80	176		●	●	●	○	○	○	
	30	40	104	●	●	●	●	●	×	×	
	30	80	176		●	●	●	○	×	×	
	50	40	104	●	●	●	●	○	×	×	
	50	80	176		●	●	●	△	×	×	
	60	40	104	●	●	●	●	●	×	×	
	60	80	176		○	●	●	○	×	×	
	70	40	104	●	●	●	●	○	×	×	
	70	80	176		○	●	●	△	×	×	
	80	40	104	●	●	●	●	●	×	×	
80	80	176		○	●	●	△				
90	40	104	○	●	●	●	△	×	×		
90	80	176		○	●	●	△				
98	40	104	△		●	○		○	○		
98	80	176			△	○					
甲苯 C ₆ H ₅ CH ₃		40	104		△	△	●				
		80	176				○				
氯氣 Cl ₂	濕	40	104	○		●	●				
		80	176			△	●				
	乾	40	104	●		●	●				
		80	176			●	●				
鉻酸 H ₂ CrO ₄	10	40	104	●		●	●				
	10	80	176			●	●				
	20	40	104	△		●	●				
	20	80	176			●	●				
	40	40	104	△		●	●				
	40	80	176			●	●				
	50	40	104	×		●	●				
	50	80	176			△	●				
	鹽酸 HCl	15	40	104	●	●	●	●	○		
		15	80	176		●	●	●			
25		40	104	●	●	●	●	×			
25		80	176		●	●	●				
35		40	104	●	●	●	●	×			
35		80	176		○	●	●				
38		40	104	●	●	●	●	×			
38		80	176		○	●	○				

● 優 ○ 好 △ 普通 × 劣

化學式	濃度 %	溫度		塑膠				橡膠	不銹鋼	
		°C	°F	PVC	PP	PVDF	PTFE	NBR	304	316
檸檬酸 C ₅ H ₈ O ₇	10	40	104	●	●	●	●	●	●	●
	10	80	176		○	●	●	●		
汽油	10	40	104	●		●	●			
	10	80	176			●	●			
柴油		40	104			●	●		●	●
		80	176			●	●		●	●
乙醇 C ₂ H ₅ OH	純	40	104	●	●	●	●	●	○	○
		80	176		○	●	●	○		
蟻酸 HCOOH	90	40	104	○	○	●	●			
		80	176			●	●			
氫氟酸 HF	稀釋	40	104	●	○	●	●	●		
		80	176		○	●	●	●		
	30	40	104	○	○	●	●	●		
		80	176	×	○	●	●	●		
	40	40	104	△	○	●	●	●		
		80	176		○	●	●	●		
	50	40	104	△	○	●	●	●		
		80	176		○	●	●	●		
雙氧水 H ₂ O ₂	5	40	104	●	●	●	●		○	●
		80	176		○	●	●			
	20	40	104	●	●	●	●			
		80	176		○	●	●			
	30	40	104	○	○	●	●			
		80	176		△	●	●			
	50	40	104	△	×	●	●			
		80	176			●	●			
	90	40	104			●	●			
		80	176			●	●			
異丙醇 (CH ₃) ₂ CHOH	純	40	104	●	●	●	●	○		
		80	176			●	●			
煤油		40	104	●	○	●	●			
		80	176			●	●			
甲醇 CH ₃ OH		40	104	○	●	●	●	△		
		80	176		○	●	●			
丁酮 CH ₃ COC ₂ H ₅		40	104		△		●			
		80	176				●			
鉻酸鉀 K ₂ CrO ₄		40	104	●	●	●	●	●		
		80	176		○	●	●	○		

開關接點保護線路

電感性負載

當磁簧開關使用在有馬達、繼電器、螺管線圈等之有電感性負載的電路中，當磁簧開路瞬間，接點間將承受一高感應電壓。這樣的感應電壓將造成磁簧開關的損壞或嚴重縮短磁簧開關的使用壽命。因此建議一些保護線路如：RC(緩衝器)、變阻器、二極體。(參考圖四)

(圖四)

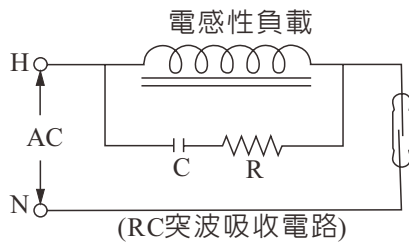

$$C = \frac{I^2}{10} (\mu F)$$

$$R = \frac{E}{10I(1 + \frac{50}{E})}$$

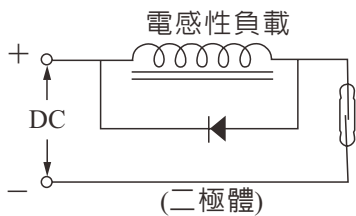
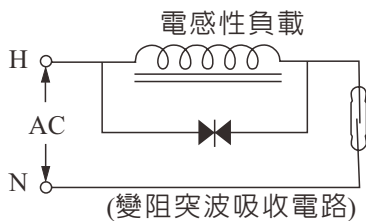

電容性負載

當磁簧開關使用在電容性負載的線路中如：電容器、白熱燈泡、很長的電纜線等，在開關的接點間將產生一個驟升(突波)電流。因此建議一些保護線路：如突波吸收器或限流電阻器。(參考圖五)

(圖五)

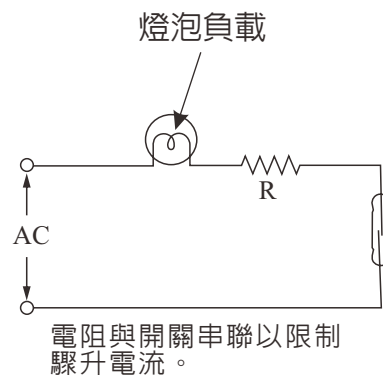
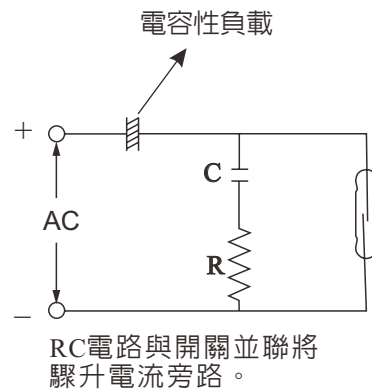

※ 請勿直接連接於電磁閥、馬達或電磁開關。

浮球規格

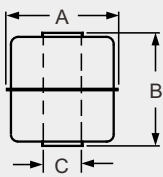
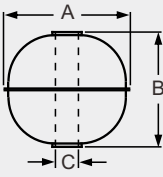
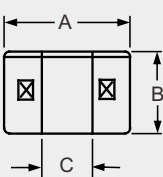
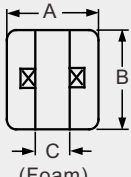
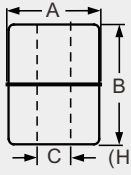
外型	型號	外觀尺寸 (mm)	比重	耐 壓 (kg/cm ²)	重 量	材 質	最大耐溫 (°C)
	S1	28x28x9.5	E>0.7	10	8	SUS316 / 316L	200
	S3	45x55x15	E>0.65	12	37.6	SUS 316	200
	S6	75x108x20	E>0.5	10	165	SUS 316	200
	S13	38x50x15	E>0.62	12	22.9	SUS 316L	200
	S2	41x38x11	E>0.7	35	19.5	SUS 316	200
	S4	52x52x15	E>0.55	30	33.4	SUS 316	200
	S5	75x73x20	E>0.70	30	102.4	SUS 316	200
	S7	30x28x9.5	E>0.75	25	8	SUS 316 / 316L	200
	S8*	100x100x20	E>0.5	15	249.7	SUS 304	200
	S9*	150x150x30	E>0.45	15	534	SUS 304	200
	S10	30x32x9.5	E>0.75	50	8.6	SUS 316	200
	S11	28x32x9.5	E>0.82	30	8.1	SUS 316	200
 <p>(Hollow)</p>	P1	25x15x10	E>0.65	4	3.5	PP / 白 黑	80
	P2	25x25x10	E>0.7	4	5	PP / 白 黑	80
	P3	48x45x18.5	E>0.6	5	35.5	PP / 黑	80
	P4	20x25x10	E>0.7	4	3.7	PP / 白 黑	80
	P5	20x20x8.1	E>0.75	4	4	PP / 白	80
	P8	18.2x15.3x7.2	E>0.8	4	1.82	PP / 黑	80
 <p>(Foam)</p>	Q6	20x20x7.5	E>0.75	ATM	3.5	PP / 白	80
	Q7	25x25x8.8	E>0.7	ATM	6.7	PP / 白	80
	N1	25x15x10	E>0.5	ATM	2.7	NBR / 黑	100
	N2	18.5x26x10	E>0.7	ATM	3.3	NBR / 黑	100
	N4	17.5x25x10	E>0.65	ATM	2.5	NBR / 黑	100
	N5	30x45x12.8	E>0.5	ATM	11.5	NBR / 黑	100
 <p>(Hollow)</p>	F2	42x44x14	E>0.45	5	18.5	PP	80
	F3	45x45x20	E>0.65	5	35.7	PP	80
	F4	48x62x18	E>0.8	5	65.3	PVDF	120

金屬單點式水平安裝型

▶ FD MH50/ 56

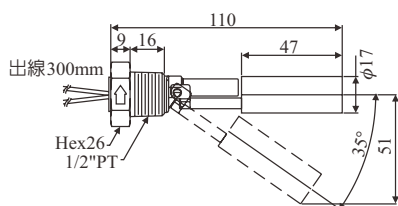

▶ FD MH50A /56A

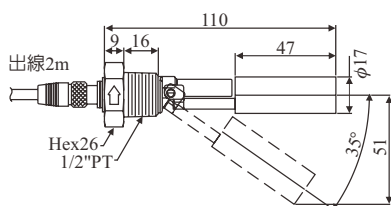

▶ FD MH50C /56C

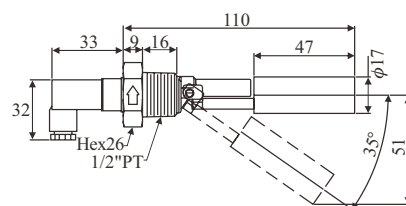

▶ FD MH60/ 66

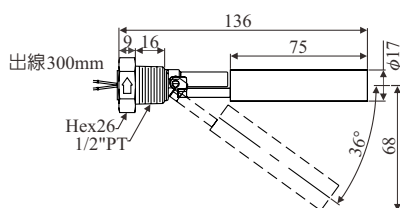

▶ FD MH60A/ 66A

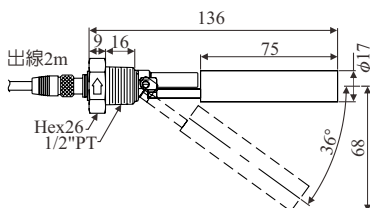

▶ FD MH60C/ 66C

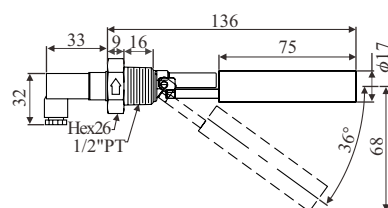

◎特性規格

型號	材質	接點容量	最高電壓	最大切換電流	最大通電電流	導線規格	最大工作壓力	工作溫度	適用比重
FDMH50/56 FDMH60/66	SUS 304 SUS 316	50W/SPST	240Vac 200Vdc	0.5A	1A	XLPE or TEFLON	5 kg/cm ²	-20~120°C (Max.200°C)	FDMH5:0.92 FDMH6:0.75
FDMH50A/56A FDMH60A/66A	SUS 304 SUS 316	50W/SPST	240Vac 200Vdc	0.5A	1A	PVC or PUR	5 kg/cm ²	80°C	FDMH5:0.92 FDMH6:0.75
FDMH50C/56C FDMH60C/66C	SUS 304 SUS 316	50W/SPST	240Vac 200Vdc	0.5A	1A	NA	5 kg/cm ²	-20~120°C	FDMH5:0.92 FDMH6:0.75

型號 / 訂購料號 對照表

型號	訂購料號
FDMH50	FDM10000-05MA
FDMH56	FDM10000-05MB
FDMH60	FDM10000-06MA
FDMH66	FDM10000-06MB
FDMH50A	FDM10000-05MAA
FDMH56A	FDM10000-05MBA
FDMH60A	FDM10000-06MAA
FDMH66A	FDM10000-06MBA
FDMH50C	FDM10000-06MAB
FDMH56C	FDM10000-05MBB

訂購說明(金屬單點式水平安裝)

FDM 1 0 0 07 08 - 09 10 11 12 13 14 15 16 17 18 19 20 21 22 23

⑦⑧ 認證

00: 無認證

⑨⑩ 型式

05: ϕ 17x47L (SG: 0.92)

06: ϕ 17x75L (SG: 0.75)

⑪⑫ 本體材質

MA: SUS 304

MB: SUS 316

⑬ 出線形式

A: M12接頭

B: DIN接頭

C: 直接出線

⑭⑮⑯⑰ 接續尺寸

A503: 1/2"PF

A501: 1/2"PT

A507: 1/2"NPT

A505: 1/2"BSP

⑱⑲⑳ 導線材質

250: Silicon(150°C)AWG24電纜線

210: Teflon(200°C)AWG24

291: XLPE(125°C)AWG22

220: PUR耐油線(for M12接頭)

000: 無

㉑㉒㉓ 出線長度

001: 100mm

008: 800mm

002: 200mm

009: 900mm

003: 300mm

010: 1000mm

004: 400mm

020: 2000mm

005: 500mm

100: 10m

006: 600mm

以此類推

007: 700mm

000: 無

※M12接頭固定2m, 5m, 10m, 15m

船用小浮球

► FDMRN5A0B

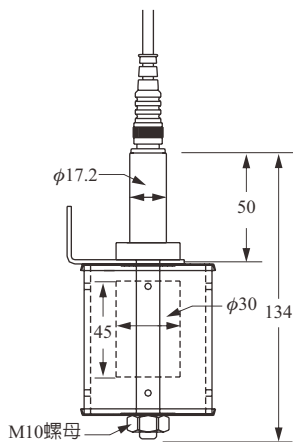

► FDMRN5B0B

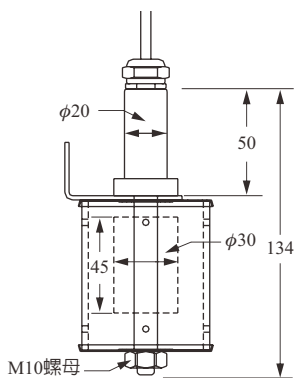

► FDMRN5C0B

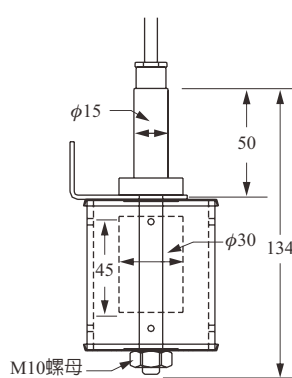

► FDMRN5D0B

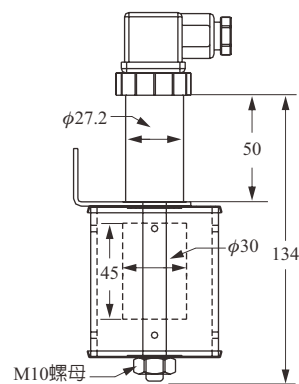

◎特性規格

型號	FDMRN5A0B	FDMRN5B0B	FDMRN5C0B	FDMRN5D0B
接點容量	50W SPST	50W SPST	50W SPST	50W SPST
最高電壓	240Vac/200Vdc			
最大切換電流	0.5A	0.5A	0.5A	0.5A
最大通電電流	1A	1A	1A	1A
操作壓力	1ATM	1ATM	1ATM	1ATM
操作溫度	Max. 80°C	Max. 80°C	Max. 100°C	Max. 80°C
接液材質	SUS304(浮球:NBR)			
適用比重	0.5			
連接器/纜線	M12接頭,出線2m	PVC 22AWG	Silicon	DIN 43650

船用小浮球

► FDMRN8A0B

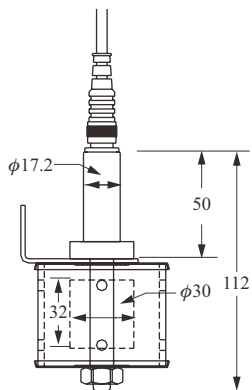

► FDMRN8B0B

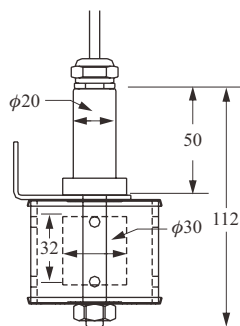

► FDMRN8C0B

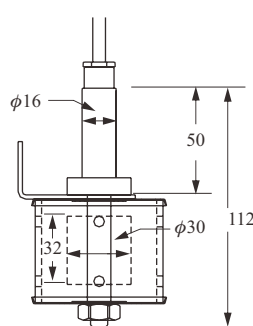

► FDMRN8D0B

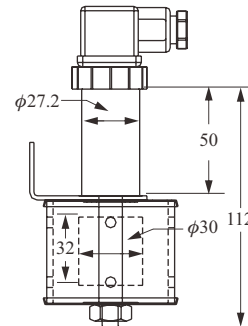

◎特性規格

型號	FDMRN8A0B	FDMRN8B0B	FDMRN8C0B	FDMRN8D0B
接點容量	50W SPST	50W SPST	50W SPST	50W SPST
最高電壓	240Vac/200Vdc			
最大切換電流	0.5A	0.5A	0.5A	0.5A
最大通電電流	1A	1A	1A	1A
操作壓力	1ATM	1ATM	1ATM	1ATM
操作溫度	Max. 80°C	Max. 80°C	Max. 100°C	Max. 80°C
接液材質	SUS304(浮球:NBR)			
適用比重	0.7			
連接器/纜線	M12接頭,出線2m	PVC 22AWG	Silicon	DIN 43650

◎FDB-0450防波管配件組

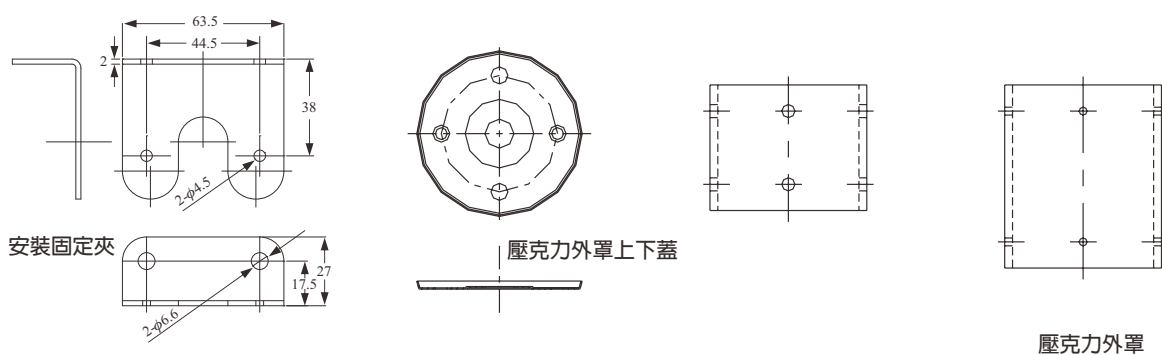

船用小浮球

FDMRN5A

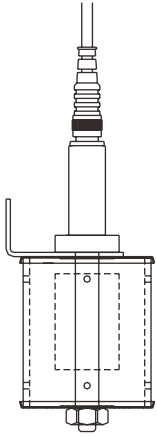

A TYPE

FDMRN5B

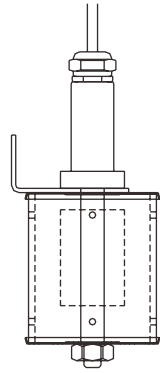

B TYPE

FDMRN5C

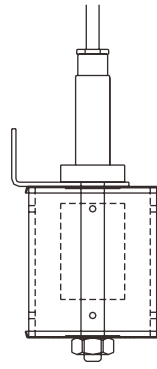

C TYPE

FDMRN5D

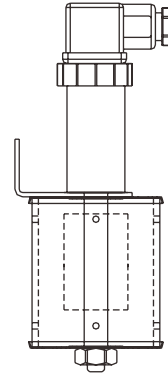

D TYPE

FDMRN8C

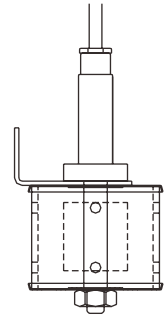

C TYPE

型號 / 訂購料號對照表

型號	訂購料號
FDMRN5A0B	FDM20000-N5MAAB
FDMRN5B0B	FDM20000-N5MACB
FDMRN5C0B	FDM20000-N5MADB
FDMRN5D0B	FDM20000-N5MABB
FDMRN8A0B	FDM20000-N8MAAB220
FDMRN8B0B	FDM20000-N8MACB233
FDMRN8C0B	FDM20000-N8MADB250
FDMRN8D0B	FDM20000-N8MABB

訂購說明(船用小浮球)

FDM 2 0 0 07 08 - 09 10 11 12 13 14 15 16 17 18 19 20

⑦⑧ 認證

00: 無認證

⑨⑩ 浮球型式材質

N5: ϕ 30x45L (NBR)

N8: ϕ 30x32L (NBR)

⑪⑫ 浮球桿材質

MA: SUS 304

MC: SUS 316L

⑬ 出線型式

A: M12接頭

B: DIN接頭

C: 電纜直接出線型式1 (B Type)

D: 電纜直接出線型式2 (C Type)

⑭ 接點型式

A: NO

B: NC

⑮⑯⑰ 導線規格

231: PVC (80°C AWG22 電纜線)

250: Silicon (150°C AWG24 電纜線)

220: PUR耐油線 (for M12接頭)

000: 無

⑱⑲⑳ 導線長度

001: 100mm

008: 800mm

002: 200mm

009: 900mm

003: 300mm

010: 1000mm

004: 400mm

020: 2000mm

005: 500mm

100: 10m

006: 600mm

以此類推

007: 700mm

000: 無

金屬單點式

▶ FD 30□1/ FD 35□1

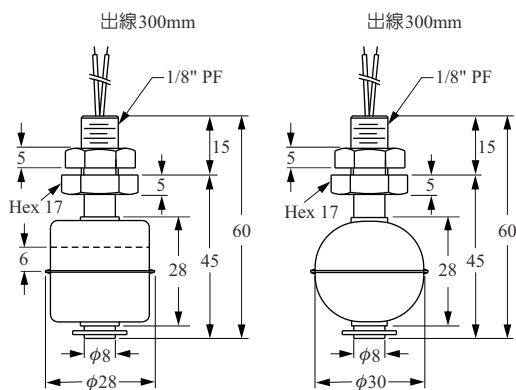
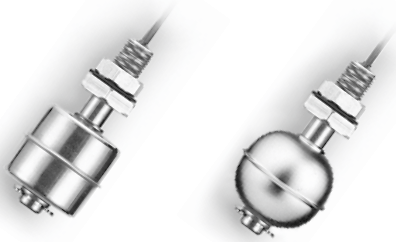

RT 墊圈：NBR
開孔尺寸：φ10mm

▶ FD 40□1

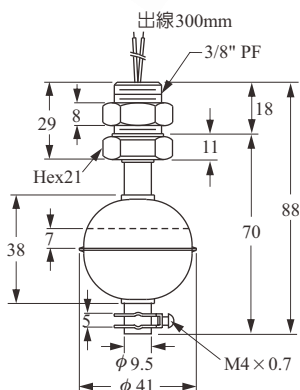

RT 墊圈：NBR
開孔尺寸：φ17mm

▶ FD 45□1

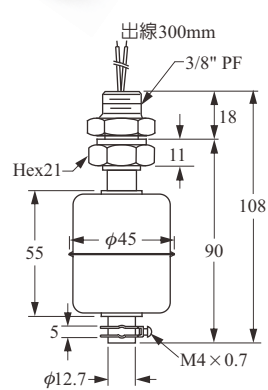

RT 墊圈：NBR
開孔尺寸：φ17mm

▶ FD 30□2

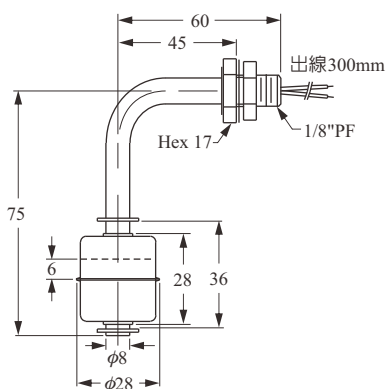

RT 墊圈：NBR
開孔尺寸：φ10mm

▶ FD 40□2

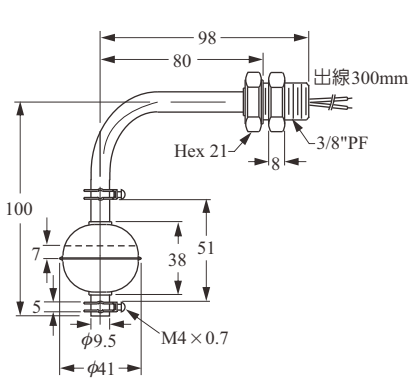

RT 墊圈：NBR
開孔尺寸：φ17mm

▶ FD 45□2

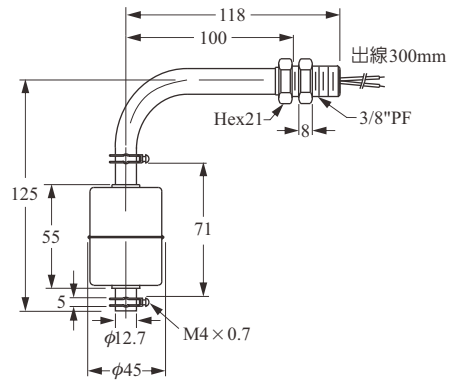

RT 墊圈：NBR
開孔尺寸：φ17mm

金屬單點式

▶ FD 50□1

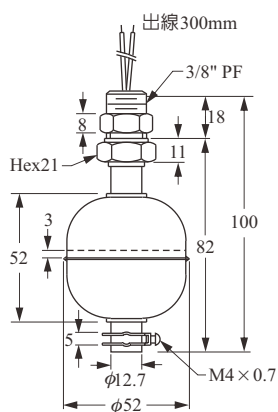

RU 墊圈：NBR
開孔尺寸：φ17mm

▶ FD 50□2

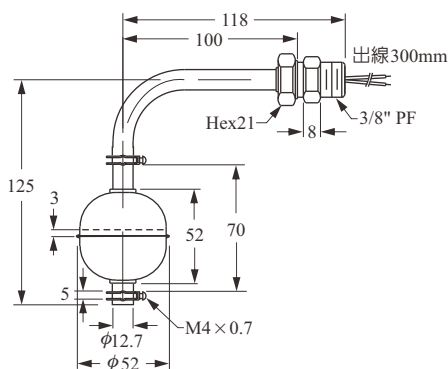

RU 墊圈：NBR
開孔尺寸：φ17mm

▶ FD 75□1

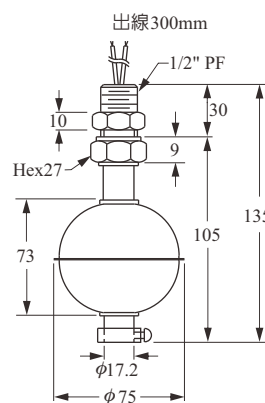

RU 墊圈：NBR
開孔尺寸：φ21mm

◎特性規格

型號	FD30□1D FD30□2D	FD40□1D FD40□2D	FD45□1D FD45□2D	FD50□1D FD50□2D	FD75□1D	FD10□1D
接點容量	50W SPST	50W SPST	50W SPST	50W SPST	50W SPST	
最高電壓	240Vac/200Vdc				220Vac	
最大切換電流	0.5A	0.5A	0.5A	0.5A	1A	
最大通電電流	1A	1A	1A	1A	2A	
導線規格	XLPE (UL3266, AWG22)					
可反轉開關動作	YES / 80°C以下, NO / 80°C以上				NO	NO
最大工作壓力	10	30	12	30	30	10
工作溫度	-20 ~120°C (200°C可訂製)					
材質	Stainless Steel SUS304, 316					
適用比重	0.7	0.7	0.65	0.55	0.65	0.5

型號 / 訂購料號 對照表

型號	訂購料號
FD30□1D	FDM30000-30□□VD
FD30□2D	FDM30000-30□□HD
FD40□1D	FDM30000-40□□VD
FD40□2D	FDM30000-40□□HD
FD45□1D	FDM30000-45□□VD
FD45□2D	FDM30000-45□□HD
FD50□1D	FDM30000-50□□VD
FD50□2D	FDM30000-50□□HD
FD75□1D	FDM30000-75□□VD
FD10□1D	FDM30000-10□□VD

訂購說明(金屬單點式)

FDM 3 ⑤⑥ ⑦⑧ ⑨⑩ ⑪⑫ ⑬⑭ ⑮⑯ ⑰⑱ ⑲⑳ ㉑

⑤⑥ 展型碼

00: 標準型
02: 高溫型

⑦⑧ 認證

00: 無認證

⑨⑩ 型式

10: ϕ 75x108, 1/2"PF	35: ϕ 30x28, 1/8"PF	45: ϕ 45x55, 3/8"PF
30: ϕ 28x28, 1/8"PF	36: ϕ 30x28, 1/8"NPT	50: ϕ 52x52, 3/8"PF
31: ϕ 28x28, 1/8"NPT	40: ϕ 41x38, 3/8"PF	75: ϕ 75x73, 1/2"PF

⑪⑫ 接液材質

MA: SUS 304
MB: SUS 316

⑬ 安裝方式

V: 垂直(上裝或下裝)
H: 水平(側裝)

⑭ 開關接點容量

D: 50W 240VAC/200VDC SPST
F: 10W 125VAC SPST
K: 20W 150VAC/200VDC SPDT

⑮ 接點型式

A: SPST, Normal Open (常開)	D: Normal Closed (常閉) 可反向安裝
B: SPST, Normal Closed (常閉)	E: Normal Open (常開) 可反向安裝
C: SPDT	

⑯⑰⑱ 導線規格

250: Silicon (150°C AWG24 電纜線)	232: PVC (80°C AWG24 電纜線)
210: Teflon (200°C AWG24)	231: PVC (80°C AWG22 電纜線)
291: XLPE (125°C AWG22)	230: PVC (80°C AWG22)
300: XLPVC (105°C AWG24)	

⑲⑳㉑ 導線長度

001: 100mm	005: 500mm	009: 900mm
002: 200mm	006: 600mm	010: 1000mm
003: 300mm	007: 700mm	020: 2000mm
004: 400mm	008: 800mm	100: 10m 以此類推

塑膠單點式(水平安裝型)

► FCH11QD

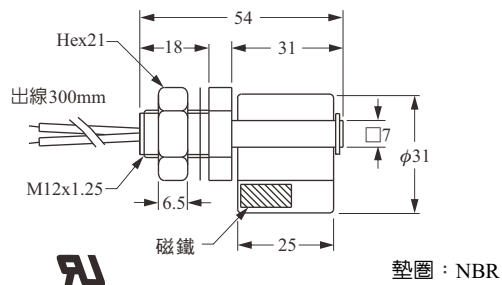

- ◇本系列產品皆有UL認證，E161587
- ◇本系列產品皆為側面安裝
- ◇比重SG是以水做參考(SG=1)

◎安裝說明

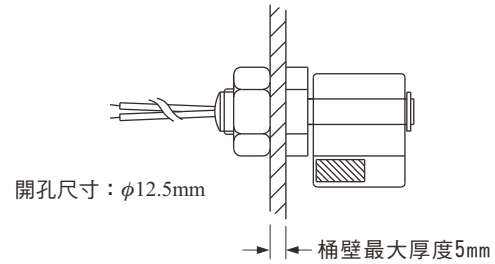

◎N.O./N.C.接點說明

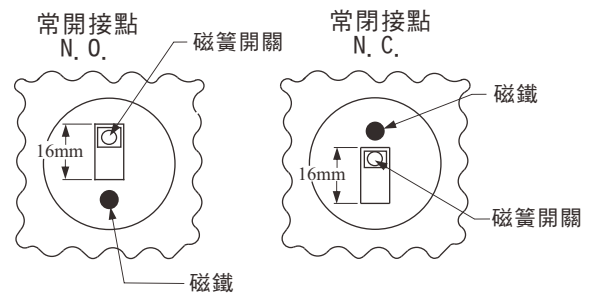

◎特性規格

型號	FCH11QD	FCH21PD FCH31PD	FCH23FD FCH33FD	FCH25GD FCH35GD
接點容量	50W SPST			
最高電壓	240VAC / 200Vdc			
最大切換電流	0.5A			
最大通電電流	1A			
導線規格	PVC AWG22	XLPE AWG22		
最大工作壓力	ATM	4 kg/cm ²	2 kg/cm ²	
工作溫度	-20~80°C		-20~120°C	
材質	PP		PVDF	Polysulfone
適用比重	0.6	0.65	0.85	0.85
重量	25 g	H21: 22 g H31: 21 g	25 g	25.4 g

塑膠單點式 (水平安裝型)

▶ FC H21PD / H31PD



- ◇ FCH2, H3 共有 2 種材質, PP、PVDF 可供選購
- ◇ 電纜或特殊導線客戶可以訂製
- ◇ 磁簧開關規格客戶可以訂製
- ◇ 歡迎 OEM 方式製造

■ FC H21PD (圓頭)

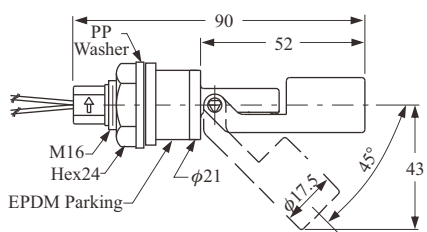

■ FC H21PD (六角頭) 可選購

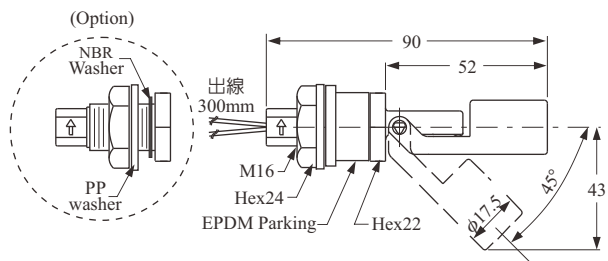

■ FC H31PD

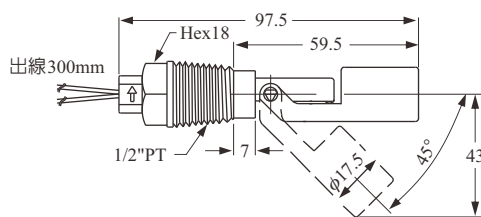

◎ 安裝說明

■ 須由桶外向桶內安裝

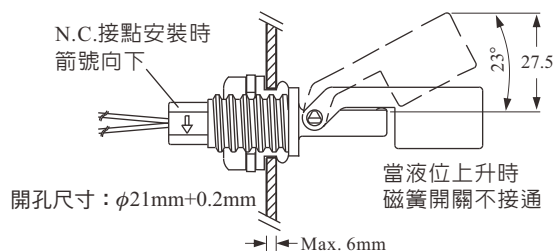

■ 須由桶內向桶外安裝

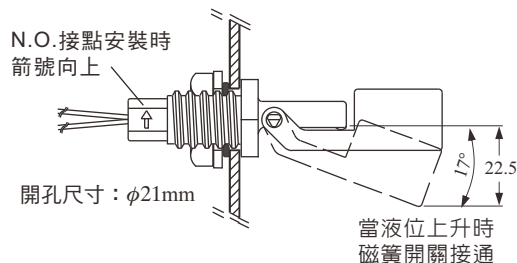

■ 須由桶外向桶內安裝

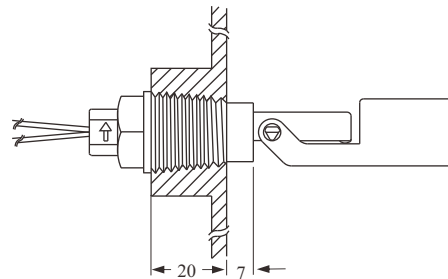

塑膠單點式(水平安裝型)

► FC H41PD / H51PD



■ FC H41PD

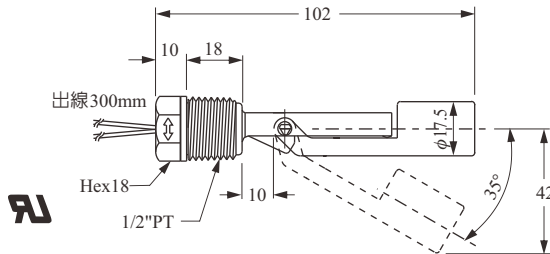

■ FC H51PD

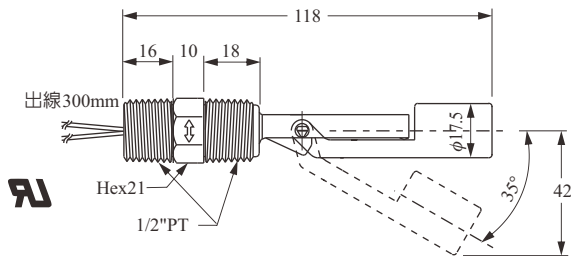

■ FC H61PD

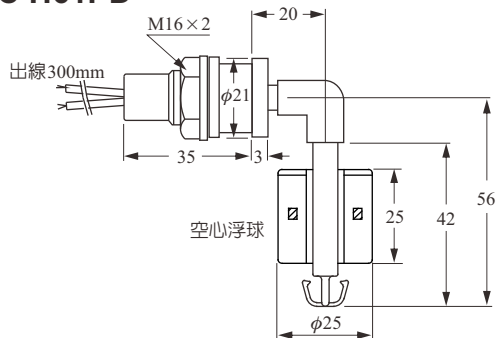

◎安裝說明

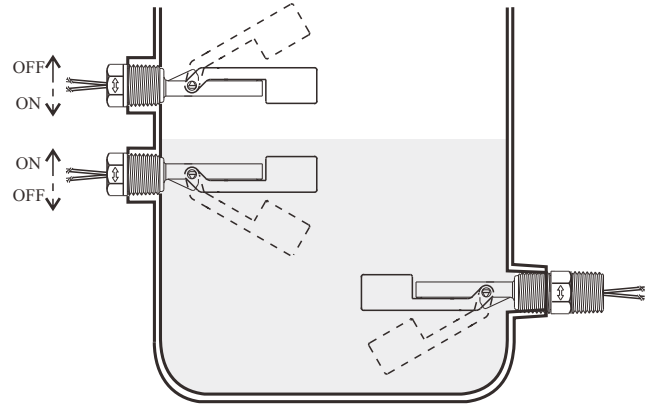

◎N.O.接點安裝說明

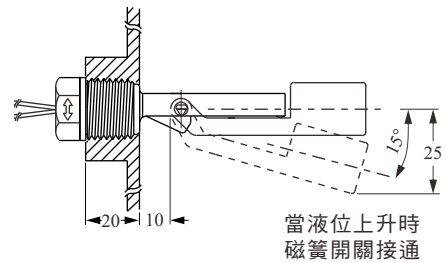

◎N.C.接點安裝說明

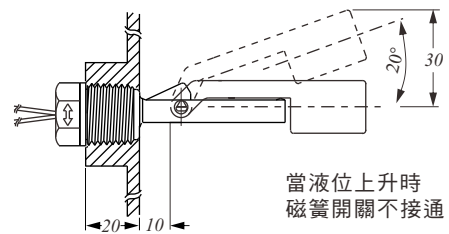

◎特性規格

型號	材質	接點容量	最高電壓	最大切換電流	最大通電電流	導線規格	最大工作壓力	工作溫度	適用比重	重量
FCH41PD	PP	50W/SPST	240Vac 200Vdc	0.5A	1A	XLPE	4 kg/cm ²	-20~80°C	0.55	20g
FCH51PD						PVC				25g
FCH61PD										31g

塑膠單點式(垂直安裝型)

▶ FC V11QF

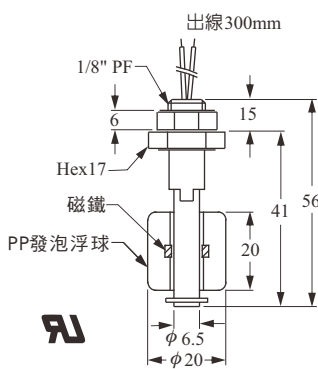

墊圈：NBR
開孔尺寸：φ10mm

▶ FC V21QD

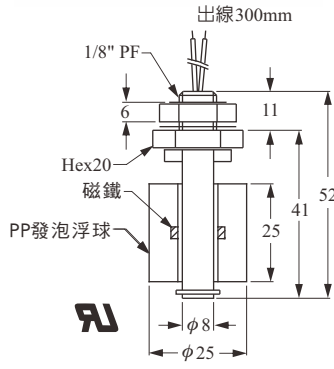

墊圈：NBR
開孔尺寸：φ10mm

▶ FC V31PD

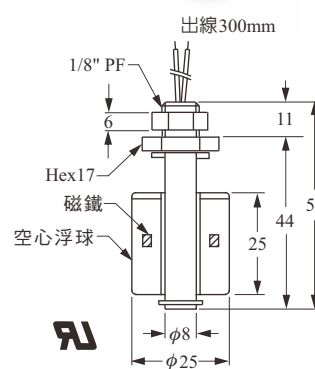

O型環：VITON
開孔尺寸：φ10mm

▶ FC V33FD, 35GD

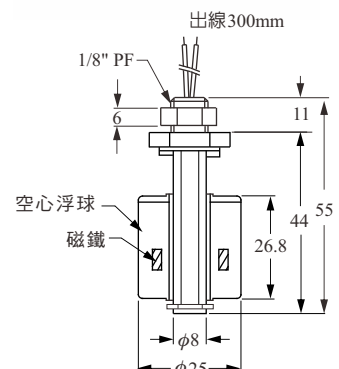

O型環：VITON
開孔尺寸：φ10mm

◎特性規格

型號	FC V11QF	FC V21QD	FC V31PD	FC V33FD	FC V35GD
接點容量	10W SPST	50W SPST	50W SPST		
最高電壓	125Vac	240Vac / 200Vdc	240Vac / 200Vdc		
最大切換電流	0.5A		0.5A		
最大通電電流	1A		1A		
導線規格	UL 1007 AWG22 PVC		UL 1007 AWG22 PVC	XLPE AWG22	
可反轉開關動作	YES	NO	YES/ 80°C以下		
最大工作壓力	ATM		4 kg/cm ²	2 kg/cm ²	
工作溫度	-20~80°C		-20~80°C	-20~120°C	
材質	PP		PP	PVDF	Polysulfone
適用比重	0.75	0.7	0.7	0.85	0.85
重量	12 g	18 g	12.8 g	18 g	18 g

塑膠單點式(垂直安裝型)

▶ FC V41PD

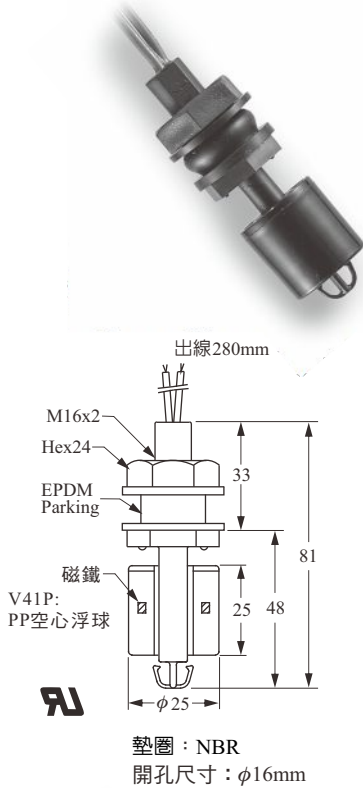

▶ FC V61PF, V61NF

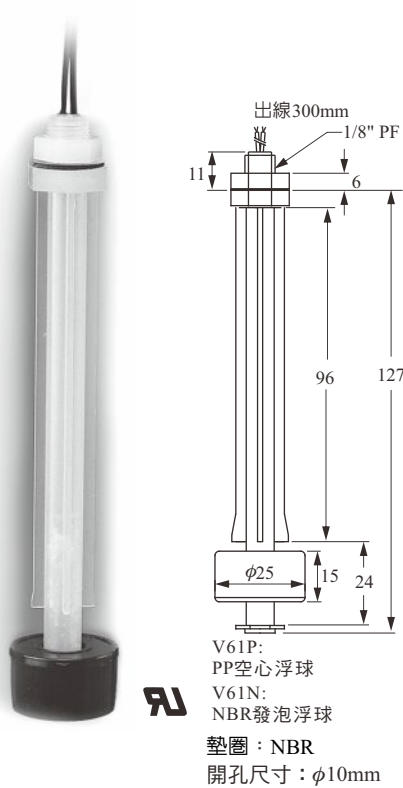

▶ FC V81PD

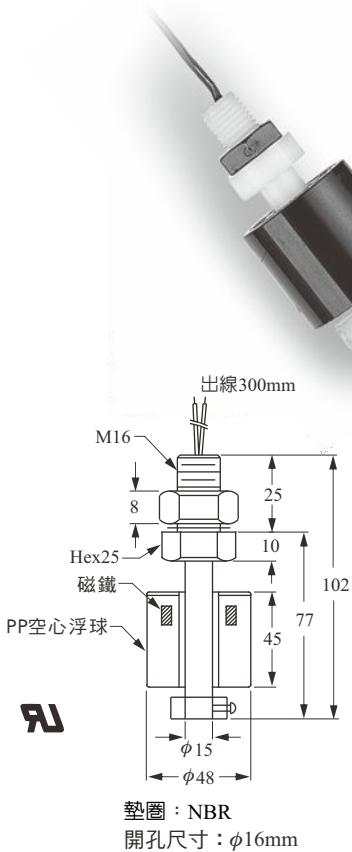

▶ FC V41ND

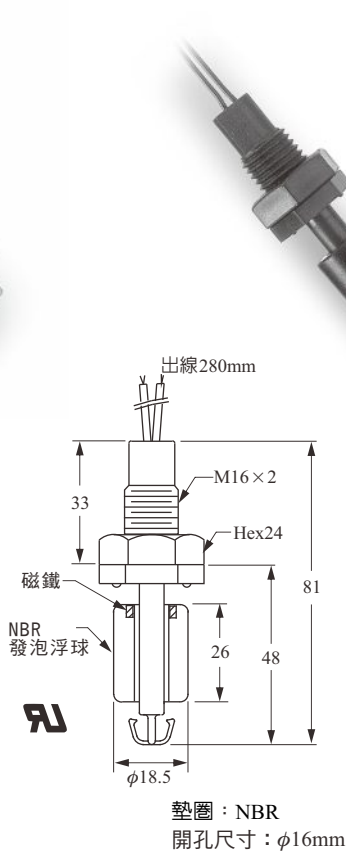

▶ FC V51PD

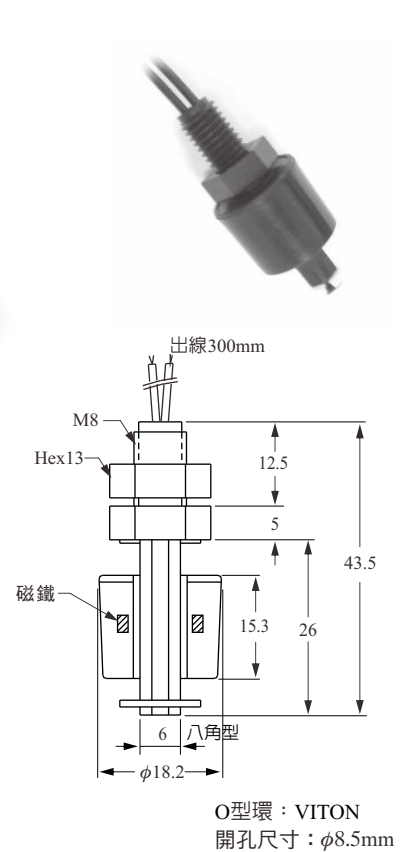

塑膠單點式(垂直安裝型)

◎特性規格

型號	FC V61PF FC V61NF	FC V41PD	FC V81PD	FC V41ND	FC V51PD
接點容量	10W SPST	50W SPST			
最高電壓	125Vac (Break Down 250Vac)	240Vac / 200Vdc			
最大切換電流	0.5A				
最大通電電流	1A				
導線規格	UL 1007 AWG22 PVC				
可反轉開關動作	NO	YES	NO	NO	NO
最大工作壓力	V61P: 4kg/cm ² V61N: ATM	4kg/cm ²	4 kg/cm ²	ATM	4 kg/cm ²
工作溫度	-20~80°C				80°C
材質	PP (except V61N, V41N: NBR float)				
適用比重	0.65 0.5	0.55	0.6	0.7	0.8
重量	16 g	23 g	180 g	17 g	8.2 g

安裝實例

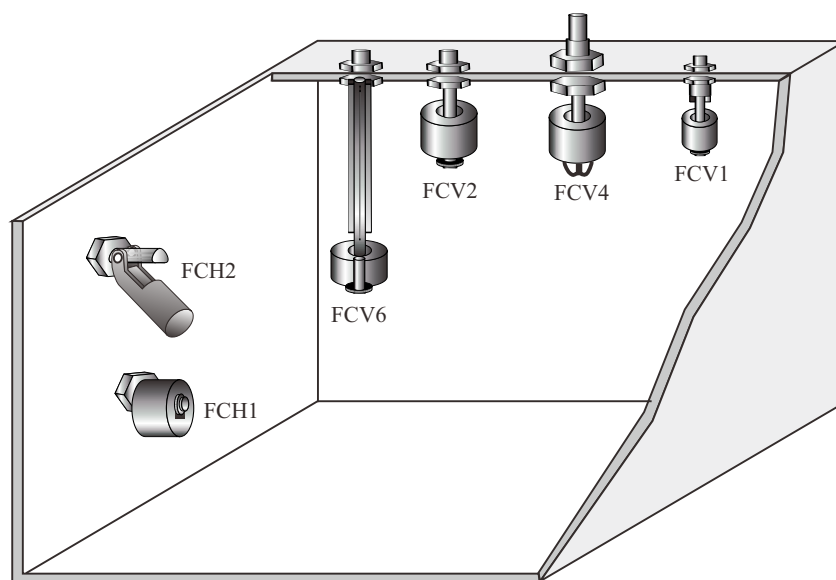

型號 / 訂購料號 對照表

型號	訂購料號
FCH11QD	FCM10000-H1181DD
FCH21PD	FCM10000-H2180D
FCH31PD	FCM10000-H3180DD
FCH23FD	FCM10000-H2240D
FCH33FD	FCM10000-H3240DD
FCH25GD	FCM10000-H2
FCH35GD	FCM10000-H3
FCH41PD	FCM10000-H4180DD
FCH51PD	FCM10000-H5180DD
FCH61PD	FCM10000-H6180D

型號	訂購料號
FCV11QF	FCM10000-V1181F
FCV21QD	FCM10000-V2181D
FCV31PD	FCM10000-V3180D
FCV33FD	FCM10000-V3240D
FCV35GD	FCM10000-V3
FCV61PF	FCM10000-V6180F
FCV61NF	FCM10000-V6070F
FCV41PD	FCM10000-V4180D
FCV81PD	FCM10000-V8180D
FCV41ND	FCM10000-V4070D
FCV51PD	FCM10000-V5180D

塑膠特殊訂製規格

※下面介紹產品為非標準品、是專為特殊場所或現有設備所做的配合設計：

▶ FC PV1

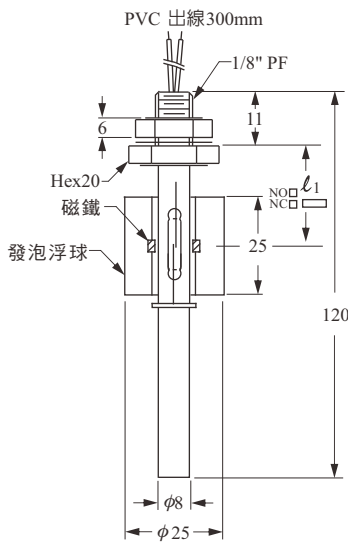

O型環：VITON

▶ FC PV2

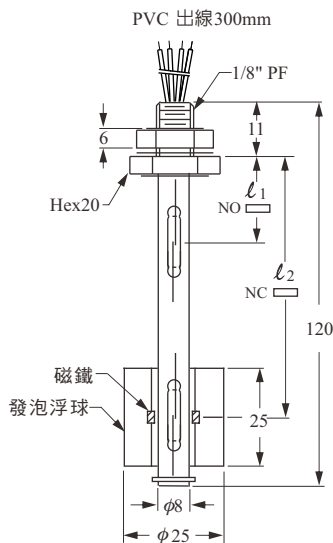

O型環：VITON

▶ FC PV3

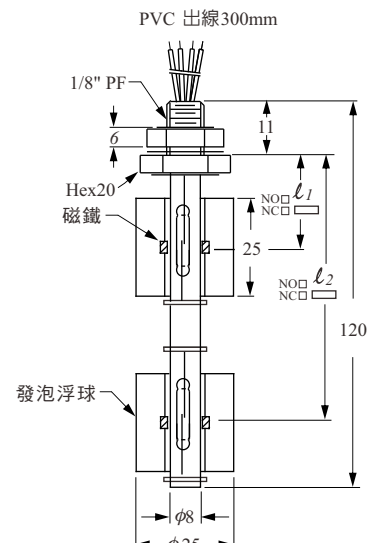

O型環：VITON

————— 浮球材質為聚丙烯(PP)，或其他訂製材質 —————

特色說明

- 1)FCPV1是單一接點輸出，控制點位置可由使用者指定製作。
- 2)FCPV2是利用單球驅動兩個位置的磁簧開關，使用者可以利用此產品做上下限水位控制。當偵測上限水位時，它的接點是浮球接近時磁簧開關ON，浮球離開時磁簧開關OFF若偵測下限水位時磁簧開關動作相反
- 3)FCPV3用兩個浮球驅動兩個位置的磁簧開關。此產品與FCPV2的差別在於它的開關接點可以做成N.O.或N.C.

型號 / 訂購料號 對照表

型號	訂購料號
FCPV1	FCM20000-V118
FCPV2	FCM20000-V2
FCPV3	FCM20000-V318

訂購說明(塑膠特殊規格)

FCM 2 0 0 ⑦⑧ ⑨⑩ ⑪⑫ ⑬ ⑭ ⑮ ⑯ ⑰ ⑱ ⑳

⑦⑧ 認證

00: 無認證

⑨⑩ 安裝型式

V1: 單浮球單點
V2: 單浮球雙點
V3: 雙浮球雙點

⑪⑫ 接液材質

18: PP浮球
07: NBR浮球, PP(桿)
24: PVDF, PP(桿)

⑬ 開關接點容量

D: 50W 240VAC/200VDC SPST
F: 10W 125VAC SPST
K: 20W 150VAC/200VDC SPDT

⑭ 接點型式

A: SPST, Normal Open (常開)
B: SPST, Normal Closed (常閉)
C: SPDT
H: 雙磁簧1-NO, 1-NC

⑮⑯⑰ 導線規格

000: 無出線
230: PVC (80°C AWG22)
231: PVC (80°C AWG22 電纜線)
232: PVC(80°C AWG24 電纜線)2球時限定使用
291: XLPE (125°C AWG22)

⑱⑲⑳ 導線長度

001: 100mm	003: 300mm	005: 500mm	008: 800mm	010: 1000mm
002: 200mm	004: 400mm	006: 600mm	009: 900mm	020: 2000mm

金屬特殊訂製規格

※下面介紹產品為非標準品、是專為特殊場所或現有設備所做的配合設計：

► FDSA□11

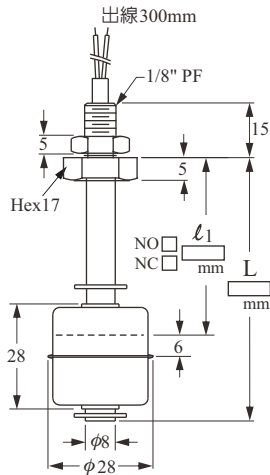

墊圈：NBR

► FDSB□11

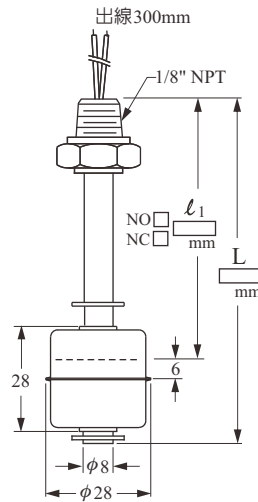

墊圈：NBR

► FDSC□11

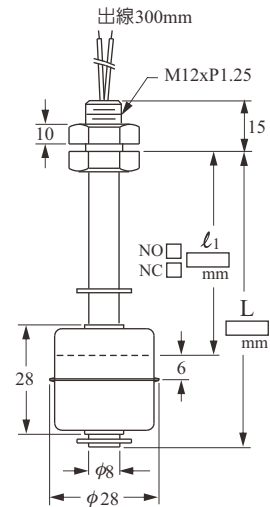

墊圈：NBR

► FDSA□12

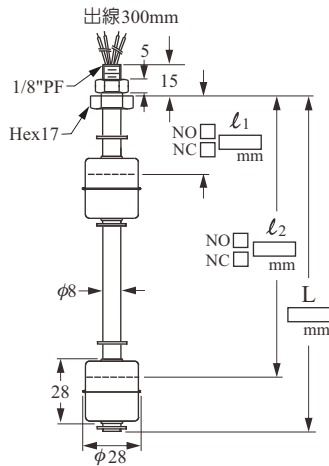

墊圈：NBR

► FDSA□21

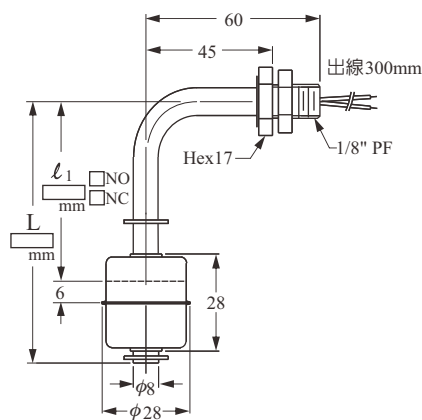

墊圈：NBR

► FDSA□22

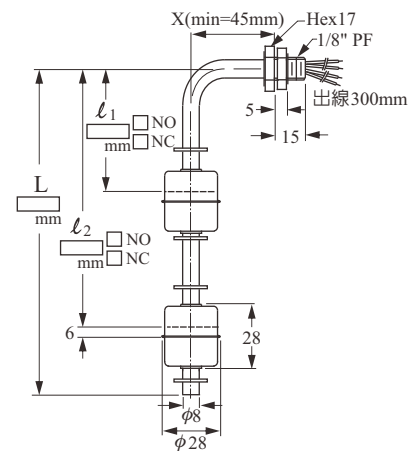

墊圈：NBR

◎特性說明

- ◇長度可以由使用者自己決定；但長度最長不能超500mm
- ◇接續螺牙可以由使用者指定
- ◇控制點可以做一點或二點
- ◇控制點可以為N.O.或N.C.

金屬特殊訂製規格

※下面介紹產品為非標準品、是專為特殊場所或現有設備所做的配合設計：

► FDSD□11

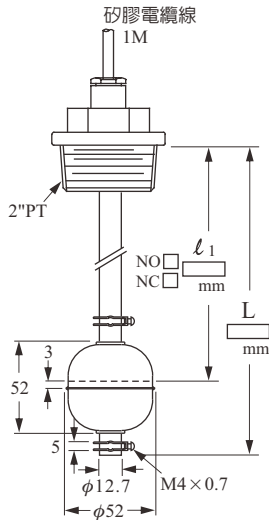

墊圈：NBR

► FDSE□11

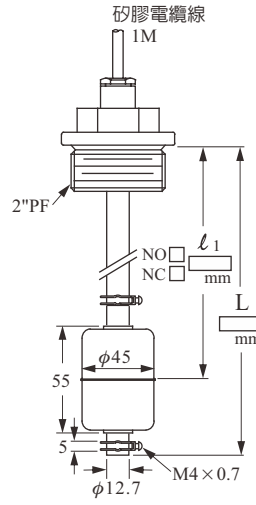

墊圈：NBR

► FDSF□11

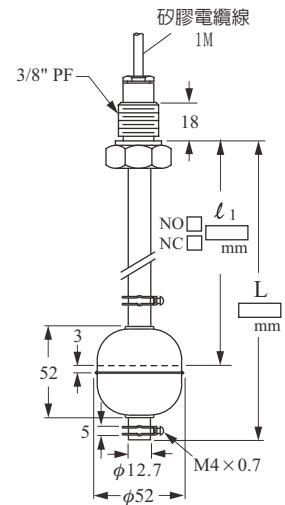

墊圈：NBR

► FD4503D

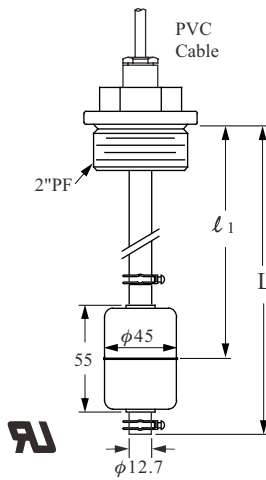

墊圈：NBR

► FD5003G

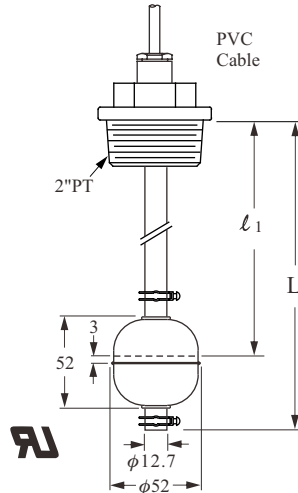

墊圈：NBR

► FD7503G

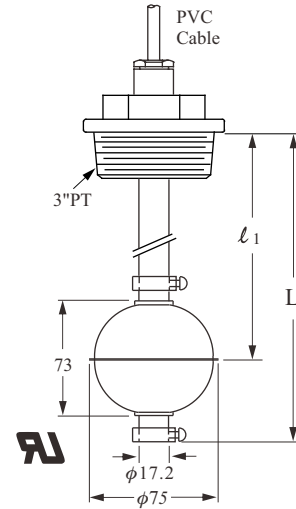

墊圈：NBR

◎特性說明

- ◇長度可以由使用者自己決定
- ◇接續螺牙可以由使用者指定
- ◇控制點可以做一點或二點
- ◇控制點可以為N.O.或N.C.

型號 / 訂購料號 對照表

型號	訂購料號
FDSA□11	FDM40000-SA
FDSB□11	FDM40000-SB
FDSC□11	FDM40000-SC
FDSA□12	FDM40000-SA
FDSA□21	FDM40000-SA
FDSA□22	FDM40000-SA
FDSD□11	FDM40000-SD
FDSE□11	FDM40000-SE
FDSF□11	FDM40000-SF

浮球開關應用線路範例

◎單一浮球，二個磁簧開關的補水控制線路。

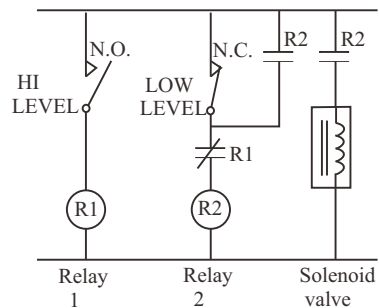
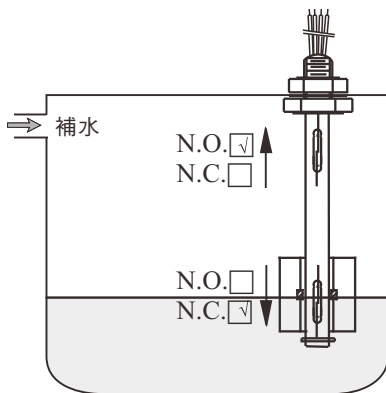

◎單一浮球，二個磁簧開關的排水控制線路。

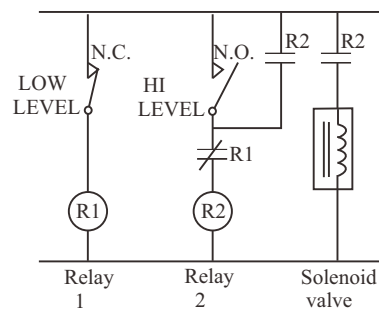
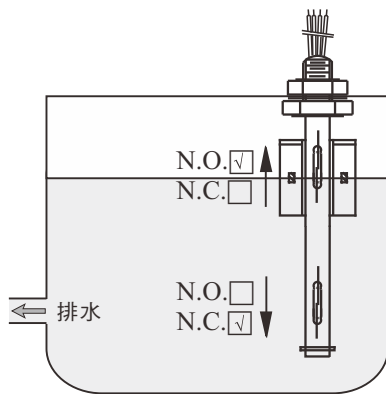

◎二個浮球，二個磁簧開關的補水控制線路。

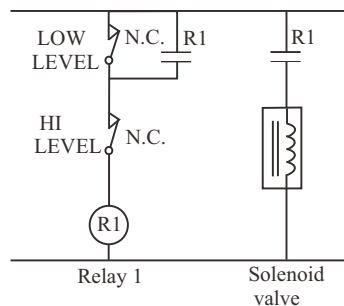
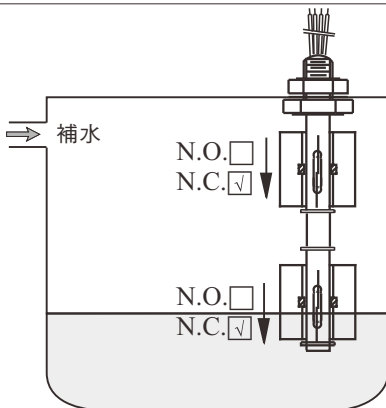

◎二個浮球，二個磁簧開關的排水控制線路。

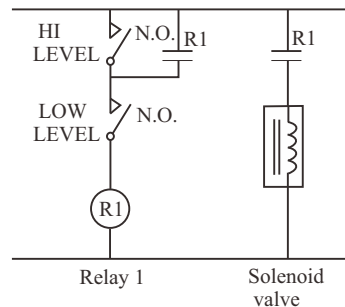
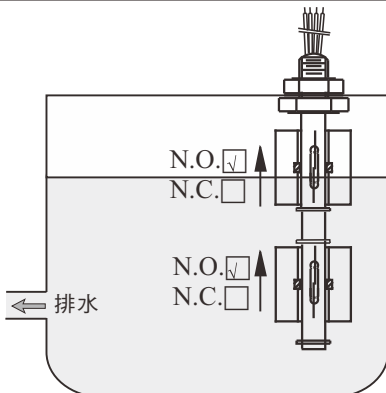

全球據點

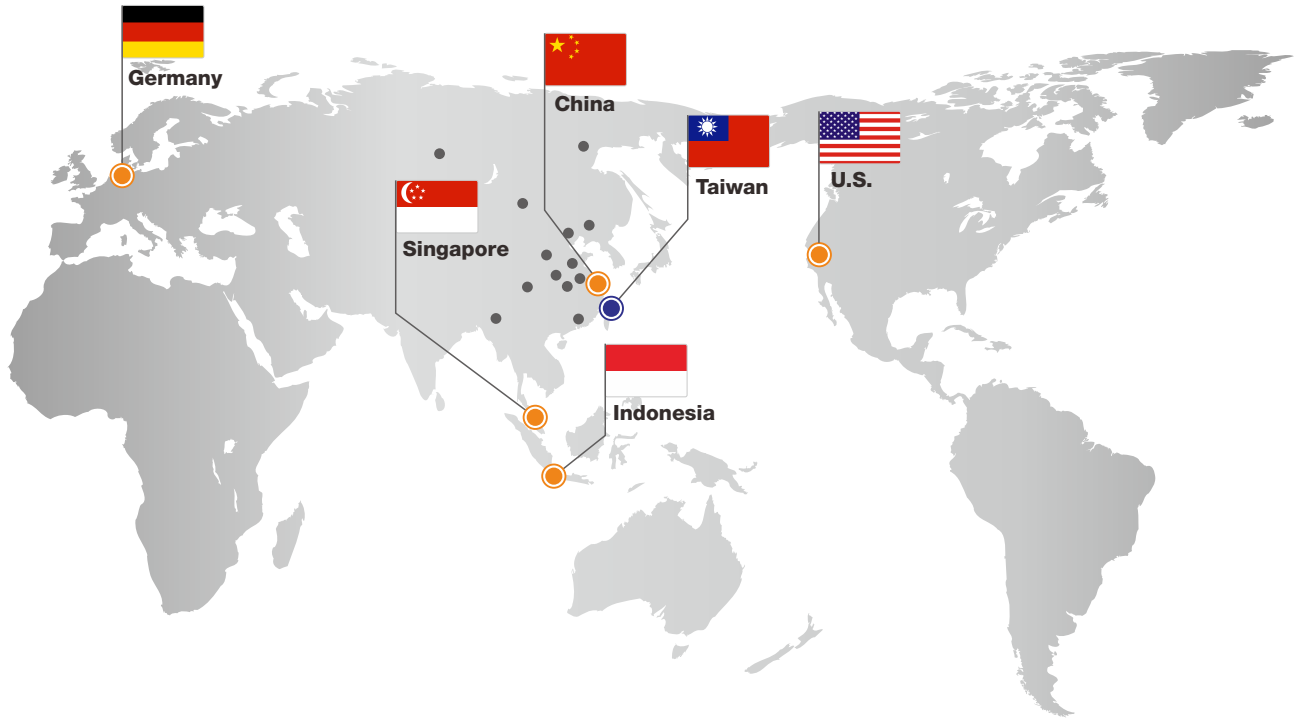

■ 總公司

- 台灣
桓達科技股份有限公司 - 臺北總公司 
23678 新北市土城工業區自強街16號
TEL: 886-2-2269-6789
FAX: 886-2-2268-6682
EMAIL: info@fine-tek.com

■ 北美洲地區

- California, U.S.
Aplus FineTek Sensor Inc. - 美國子公司
355 S. Lemon Ave, Suite D
Walnut, CA 91789
TEL: 1 909 598 2488
FAX: 1 909 598 3188
EMAIL: info@aplusfine.com

■ 歐洲地區

- 德國
FineTek GmbH - 德國子公司
Bei den Kämpen 26
21220 Seevetal-Ramelsloh, Germany
TEL: +49-(0)4185-8083-12
FAX: +49-(0)4185-8083-80
EMAIL: info@fine-tek.de

■ 亞太地區

- 中國
上海凡宜科技電子有限公司 - 上海子公司 
201109 上海市閔行區都會路451號
TEL: 86-21-6490-7260
EMAIL: info.sh@fine-tek.com

- Mütec Instruments GmbH - 德國子公司 
Bei den Kämpen 26
21220 Seevetal-Ramelsloh, Germany
TEL: +49-(0)4185-8083-0
FAX: +49-(0)4185-8083-80
EMAIL: muetec@muetec.de

- 新加坡
FineTek Pte Ltd. - 新加坡子公司
37 Kaki Bukit Place, Level 4 Singapore 416215
TEL: 65-6452-6340
EMAIL: info.sg@fine-tek.com

- 印尼
PT. FineTek Automation Indonesia - 印尼子公司 
PERGUDANGAN TUNAS BITUNG
JL. Raya Serang KM. 13,8, Blok C3 No. 12&15, Bitung Cikupa,
Tangerang 15710
TEL: +62 (021) 2958 1688
EMAIL: info.id@fine-tek.com



經銷商: