

EPU Clamp-On Ultrasonic Flow Meter



WORKING PRINCIPLE

EPU Clamp-on ultrasonic flow meter measure by using ultrasonic pulse waves to pass through the probe and strike the liquid material. While the pulse waves rapidly disperse through the liquid, the liquid flow will cause a small change in the rate at which the pulse waves are spread. This change in time at which the pulse waves are dispersed is proportional to the flow rate of the liquid. Hence, the flow rate of the liquid is derived.

As show in the figure below: A pair of ultrasonic sensors are installed opposite each other on the flow pipe in specific positions using the "Z" method and "V" method. One of the sensors is electrically charged and emits ultrasonic pulse waves, which passes through the tube wall > liquid > tube wall and is received by the other sensor. According to the upstream and reverse flow direction, the ultrasonic pulse wave dispersion time from start to end is:

$$T_{UP} = \frac{M \times D / \cos \theta}{C_0 + V \sin \theta}$$

$$T_{DOWN} = \frac{M \times D / \cos \theta}{C_0 - V \sin \theta}$$

$$DT = T_{DOWN} - T_{UP}$$

According to the formula, the liquid's average flow rate in a straight line is calculated as:

$$V = \frac{M \times D}{\sin 2\theta} \cdot \frac{\Delta T}{T_{UP} \cdot T_{DOWN}}$$

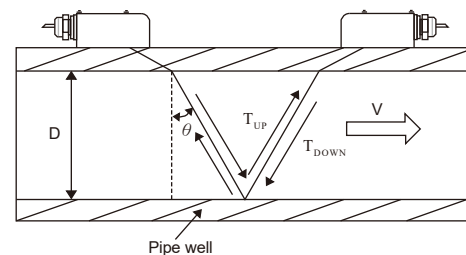

FEATURES

- No intrusion in the pipeline during measurement of flow rate, hence no adverse effects will be caused on the pipeline or process liquid.
- LCM display of instantaneous flow rate and cumulative amount.
- Standard 4-20mA, pulse wave output, RS485 Modbus communication.
- High-quality, durable, and reliable.
- Applicable to all types of liquids that without air, sediment or sludge.
- Able to measure both volume and flow rate of liquid.
- Languages on operation interface: traditional Chinese, simplified Chinese, and English.

APPLICATION IN ENVIRONMENT

- Food manufacturing industry
- Beverage manufacturing industry
- Water treatment industry
- Pharmaceutical industry
- Chemical industry
- Semiconductor industry



SPECIFICATIONS

Display size	LCM 128*64 pixels, back light
Buttons	3 control buttons
Communication interface	RS-485(Modbus)
Measurement system	Transit-time measurement method
Analog output	4~20mA
Pulse width	Automatic(pulse width 50%)
Pulse mode	NPN transistor output 32VDC/200mA
Pipe diameter size	DN32~DN150 / DN150~ DN800
Measurement range	Flow rate 0~15m/s
Accuracy	0.6~3 m/s , ±0.2% F.S.(Note1) 3~15 m/s , ±1% O.R.(Note1)
Repetition rate	0.5%
Ambient temperature	-20~60°C
Power supply	18~32 VDC/100~240 VAC
Power consumption	10 VA
Inlet specification	M20 x 1.5
Protection level	IP67
EMC	IEC 61326

Note 1:

FineTek actual flow testing equipment.

Liquid temperature: 20±10°C/Ambient temperature: 20±5°C

Length of straight pipe section: Upstream side 15 D or more; downstream side 5 D or more.

When in a fixed environment, take note of the linearity value + error range + repeatability value.

The measured result may produce errors due to the type/state of the pipeline, the type of fluid being measured, the temperature of the fluid, etc.

DIMENSIONS DRAWING

(Unit:mm)

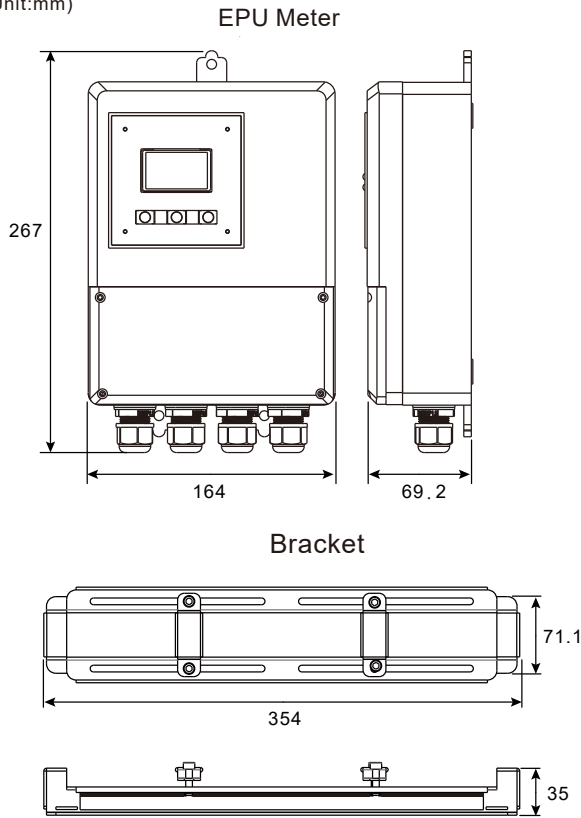

S200 EPU Transducer (DN32~DN150)

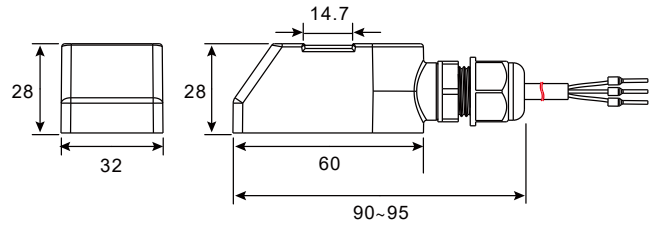

S800 EPU Transducer (DN150~DN800)

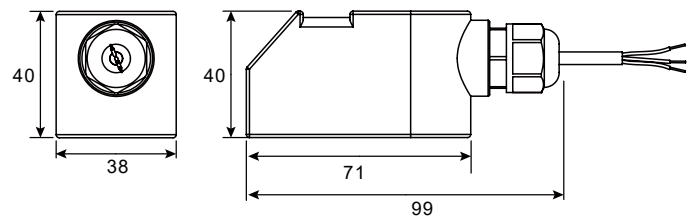

APPLICATION EXAMPLES



Food industry – pure water boiler pipe



Copper industry – tap water pipe

ORDER INSTRUCTIONS

EPU 1 ^⑮ ^⑯ 0 0 - ^⑰ ^⑱ ^⑲ ^⑳ ^㉑ ^㉒ ^㉓ ^㉔ 1 ^⑳ ^㉕ ^㉖ 0 0

⑮ ⑯ **Display code**

04: Separate type

⑰ **Operating principle**

0: Transit-time

⑱ **Power supply**

D: 24VDC
A: 100~240VAC

⑲ ⑳ ㉑ ㉒ **Transducer**

S200: Separate type DN32~DN150

S800: Separate type DN150~DN800

*S800(DN200~DN800):The metal bracket without transducer enclosed.

⑳ ㉕ **Cable length**

03: 3M
05: 5M
10: 10M
20: 20M

*DN32~DN150 is suitable with 3M、5M、10M Cable length

*DN150~DN800 is suitable with 5M、10M、20M Cable length

㉕ ㉖ **Output method**

0: Standard

