



www.fine-tek.com

## 側裝式浮球液位開關



Innovation · Quality · Sharing

# 產品簡介

## 動作原理

"側裝式浮球液位開關"是利用液體浮力原理，當浮球因浮力作用而上下運動時，接線盒內的磁簧開關受到臂端磁鐵影響，而作"NC"接點與"NO"接點之互換。同樣地原理運用在微動開關裝置上，微動開關前之磁鐵和臂端磁鐵作互斥運動而推壓微動開關，造成"NC"和"NO"動作。

## 特點

"側裝式浮球液位開關"為桶槽內水平裝置的液位偵測器，可用於高低液位偵測，其特點如下：

- 可選擇"微動開關"或"磁簧開關"。
- 接液部材質可選用SUS304或SUS316；  
防爆型亦可以製造。
- 法蘭規格可以訂製。
- 多種浮球規格，亦可適用各種不同比重之液體。

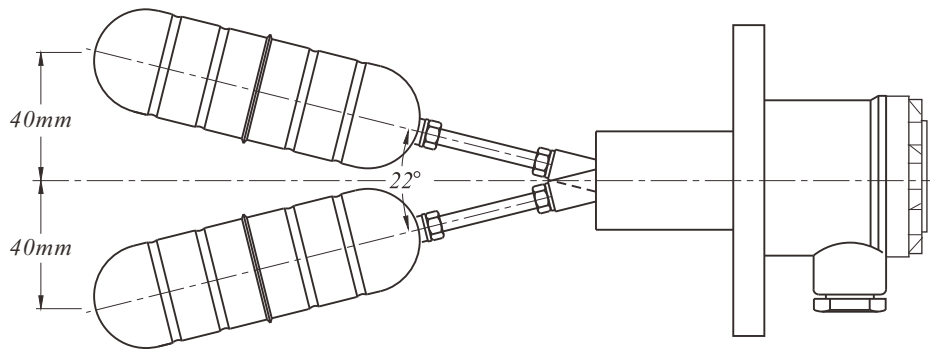

## 接線圖

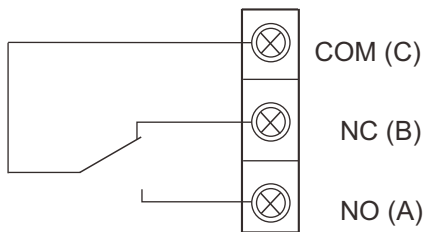

磁簧開關---1A,60W 220Vac/200Vdc (FF2□, FF45, FF55)  
1A,50W 220Vac/200Vdc (FF30, SPST)  
1A,30W 220Vac/200Vdc (FF8□)  
微動開關---5A/250Vac (FF1□, FF40, FF50, FF90, FF62)  
3A/250Vac (FF7□)

# 標準規格

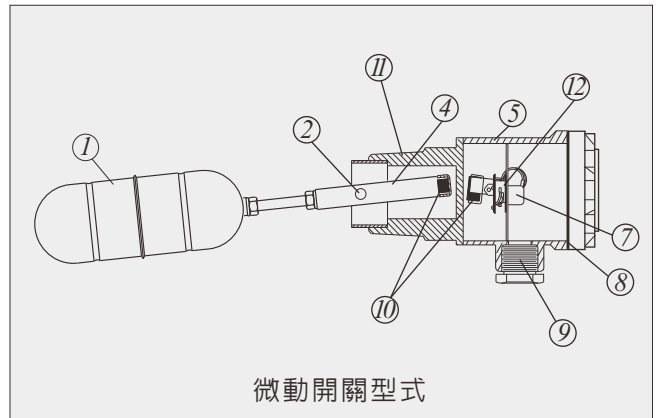
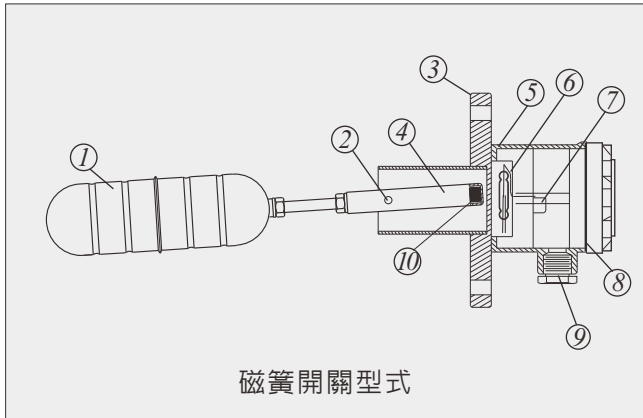

- |        |         |          |
|--------|---------|----------|
| 1. 浮球  | 5. 接線盒  | 9. 出線口   |
| 2. 固定軸 | 6. 磁簧開關 | 10. 磁鐵   |
| 3. 法蘭  | 7. 端子   | 11. 牙口   |
| 4. 臂   | 8. O型環  | 12. 微動開關 |

## 連接管長度

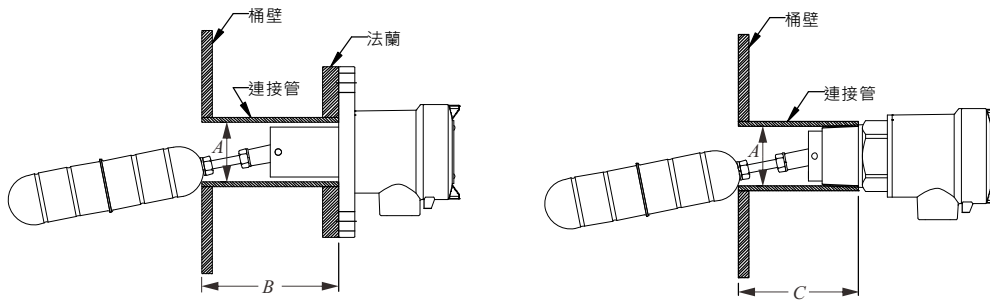

用戶過程接續之連接管長度須配合管徑，如果太長將影響浮球開關正常動作，連接管允許最大長度如下表所示：

(單位：mm)

連接管內徑 (A)	浮球 Ø41X150L		浮球 Ø50X150L		浮球 Ø75X120L	
	法蘭型 max.(B)	牙口型 max.(C)	法蘭型 max.(B)	牙口型 max.(C)	法蘭型 max.(B)	牙口型 max.(C)
45	102	91	⊕	⊕	⊕	⊕
50	103	92	102	91	⊕	⊕
55	105	94	103	92	⊕	⊕
60	108	97	106	95	⊕	⊕
65	112	101	107	96	⊕	⊕
70	122	111	110	99	⊕	⊕
75	135	124	114	103	106	95
80	148	137	124	113	107	96
85	161	150	137	126	109	98
90	170	159	150	139	112	101
95	186	175	163	152	115	104
100	199	188	169	158	119	108
105	212	201	188	177	125	114
110	225	214	201	190	136	125
115	⊙	⊙	214	203	149	138
120	⊙	⊙	⊙	⊙	162	151
125	⊙	⊙	⊙	⊙	174	163
130	⊙	⊙	⊙	⊙	⊙	⊙

⊕：浮球直徑大於孔徑無法穿入。

⊙：連接管長度不受限制。

# 規格表



型號	規格	操作溫度	接點型式	接點容量	接點元件	接線盒	適用比重
FF10BHM		-20°C~100°C	SPDT(1C)	5A/250Vac	微動開關	鋁合金 IP65	0.25
FF10CEM		-20°C~100°C	SPDT(1C)	5A/250Vac	微動開關	鋁合金 IP65	0.65
FF10CEQ		-20°C~100°C	SPDT(1C)	5A/250Vac	微動開關	鋁合金 IP65	0.65
FF10CLO		-20°C~100°C	SPDT(1C)	5A/250Vac	微動開關	鋁合金 IP65	0.65
FF10DFM		-20°C~100°C	SPDT(1C)	5A/250Vac	微動開關	鋁合金 IP65	0.55
FF10DFQ		-20°C~100°C	SPDT(1C)	5A/250Vac	微動開關	鋁合金 IP65	0.55
FF15HEQ		-20°C~100°C	SPDT(1C)	5A/250Vac	微動開關	SUS304 IP65	0.8
FF12CEM		-40°C~100°C	SPDT(1C)X2	5A/250Vac	微動開關	鋁合金 IP65	0.65
FF20BHM		-40°C~200°C	SPDT(1C)	1A, 60W 220Vac/200Vdc	磁簧開關	鋁合金 IP65	0.25
FF20CEM		-40°C~200°C	SPDT(1C)	1A, 60W 220Vac/200Vdc	磁簧開關	鋁合金 IP65	0.65
FF20CEQ		-40°C~200°C	SPDT(1C)	1A, 60W 220Vac/200Vdc	磁簧開關	鋁合金 IP65	0.65
FF20DFM		-40°C~200°C	SPDT(1C)	1A, 60W 220Vac/200Vdc	磁簧開關	鋁合金 IP65	0.55
FF20DFQ		-40°C~200°C	SPDT(1C)	1A, 60W 220Vac/200Vdc	磁簧開關	鋁合金 IP65	0.55
FF20DLO		-40°C~200°C	SPDT(1C)	1A, 60W 220Vac/200Vdc	磁簧開關	鋁合金 IP65	0.55

※以上型均有船級認證 DNV-GL、LR、BV、ABS。

# 規格表



規格 型號	操作溫度	接點型式	接點容量	接點元件	接線盒	適用比重
FF40DFM	-20°C~100°C	SPDT(1C)	5A/250Vac	微動開關	鋁合金 IP65	0.55
FF45DFM	-40°C~200°C	SPDT(1C)	1A, 60W 220Vac/200Vdc	磁簧開關	鋁合金 IP65	0.55
FF50DFM	-20°C~100°C	SPDT(1C)	5A/250Vac	微動開關	鋁合金 IP65	0.55
FF55DFM	-40°C~200°C	SPDT(1C)	1A, 60W 220Vac/200Vdc	磁簧開關	鋁合金 IP65	0.55
FF70/71BHM	-20°C~100°C	SPDT(1C)	3A/250Vac	微動開關	SUS316 Ex d, Ex tb	0.25
FF70/71CFM	-20°C~100°C	SPDT(1C)	3A/250Vac	微動開關	SUS316 Ex d, Ex tb	0.65
FF70/71DFM	-20°C~100°C	SPDT(1C)	3A/250Vac	微動開關	SUS316 Ex d, Ex tb	0.55
FF73GLO	-20°C~100°C	SPDT(1C)	3A/250Vac	微動開關	SUS316 Ex d, Ex tb	0.7
FF75DFM	-20°C~100°C	SPDT(1C)	3A/250Vac	微動開關	SUS316 Ex d, Ex tb	0.55
FF90CLO 	-20°C~100°C	SPDT(1C)	5A/250Vac	微動開關	鋁合金 IP65	0.65

※以上型均有船級認證 DNV-GL、LR、BV、ABS。

規格 型號	操作溫度	接點型式	接點容量	接點元件	接線盒	適用比重
FF30A3Q	-20°C~100°C	SPST(1A)	1A, 50W 220Vac/200Vdc	磁簧開關	SUS304 IP65	0.65
FF62DFM	-40°C~350°C	SPDT(1C)	5A/250Vac	微動開關	鋁合金 IP65	0.55
FF80EFM	-20°C~80°C	SPDT(1C)	1A, 30W 220Vac/200Vdc	磁簧開關	PC IP65	0.60
FF81E	-20°C~80°C	SPDT(1C)	1A, 30W 220Vac/200Vdc	磁簧開關	—	0.60

# 標準型

▶ FF10BHM

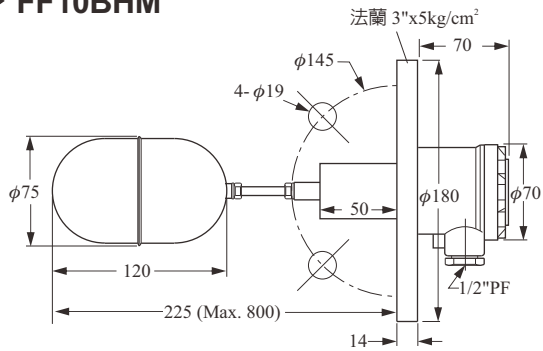

▶ FF10CEM

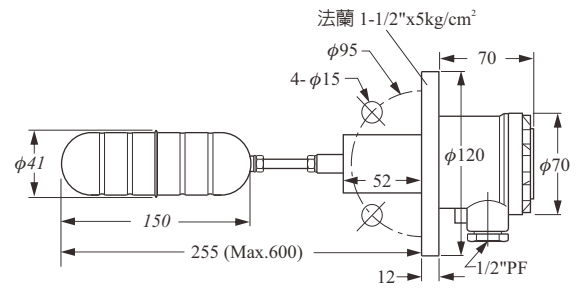

▶ FF10CLO

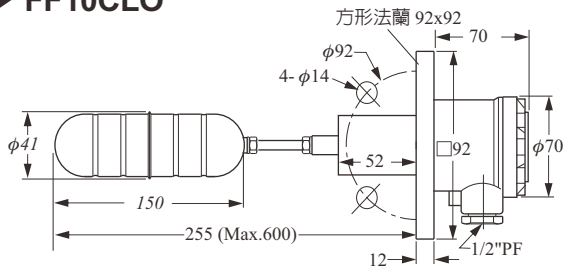

▶ FF10CEQ

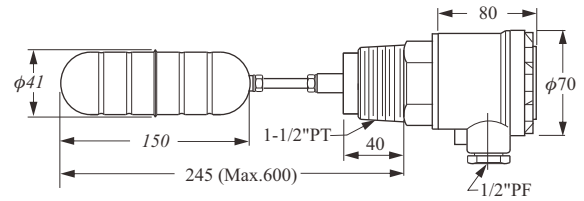

▶ FF10DFM

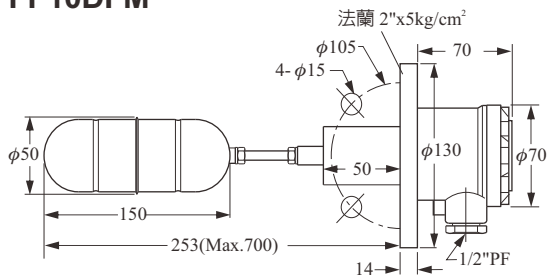

▶ FF10DFQ

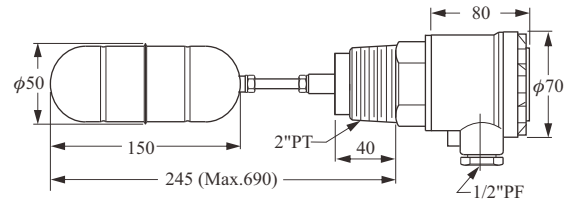

▶ FF15HEQ

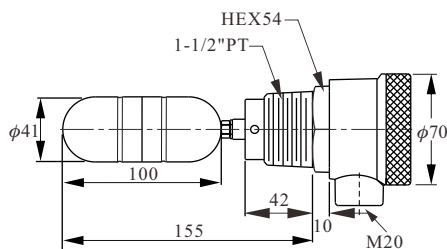

▶ FF12CEM

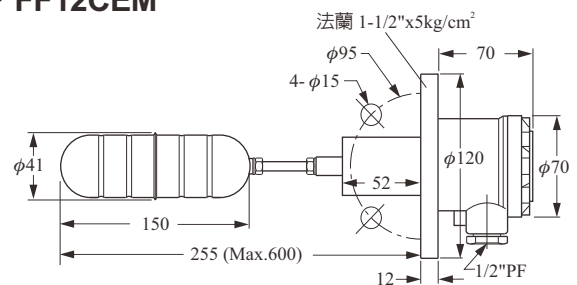



# 高溫型

► FF20BHM

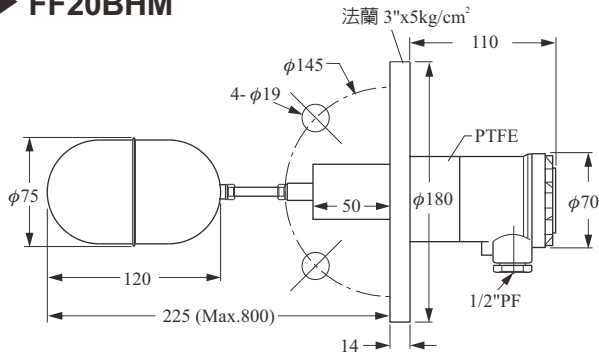

► FF20CEM

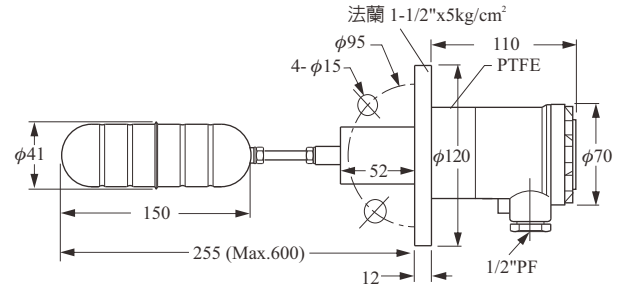

► FF20CEQ

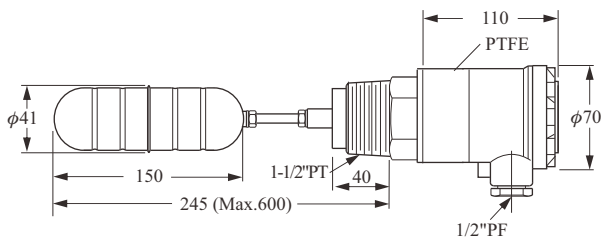

► FF20DFM

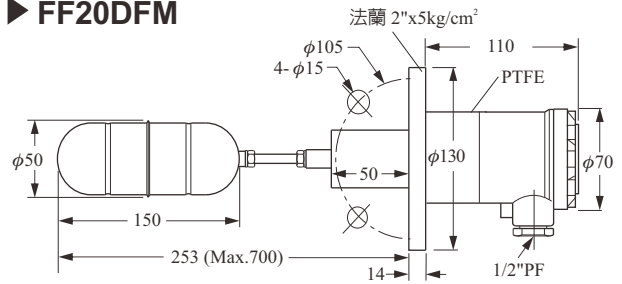

► FF20DLO

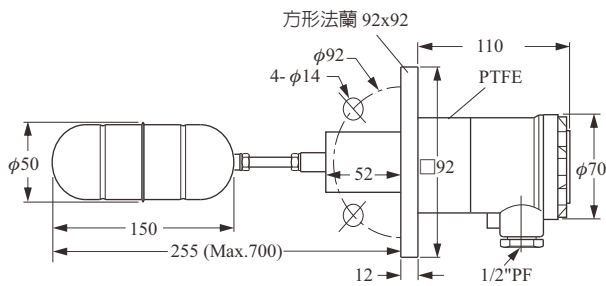

► FF20DFQ

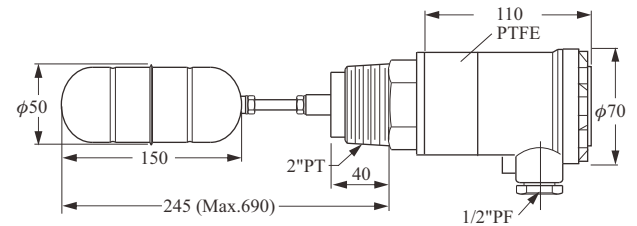

► FF62DFM

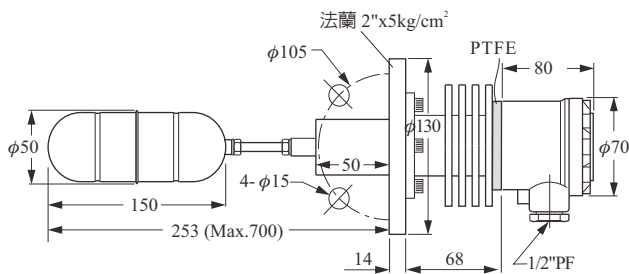

# 雙曲型/上裝型

## ► FF40DFM

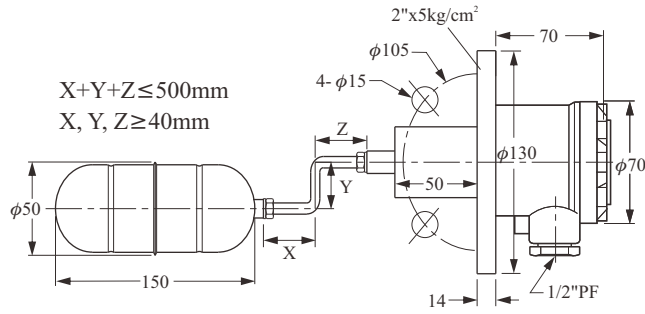

## ► FF50DFM

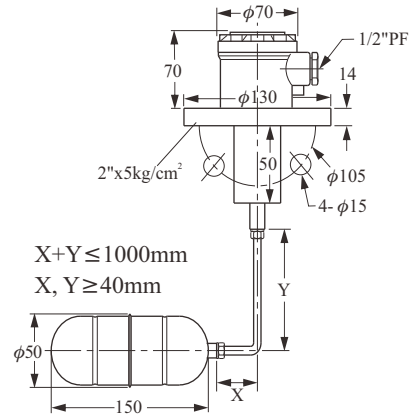

## ► FF45DFM

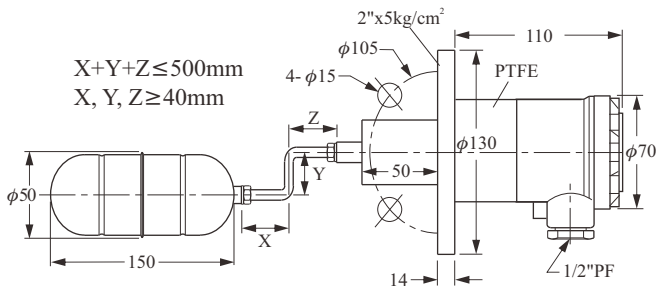

## ► FF55DFM

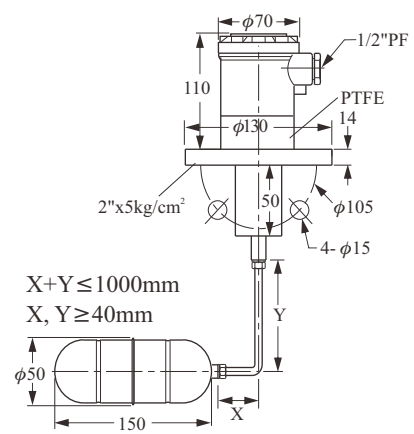

## ► FF30A3Q

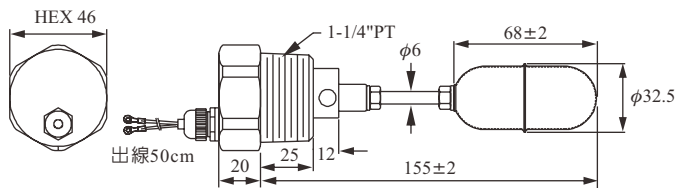



# 耐酸鹼型

## 動作原理

當液體淹滿至本液位計時，PP浮球受浮力而上昇。此時，浮球內的永久磁鐵便能感應本體結構的磁簧開關而作"ON"和"OFF"的切換。

### ► FF80EFM

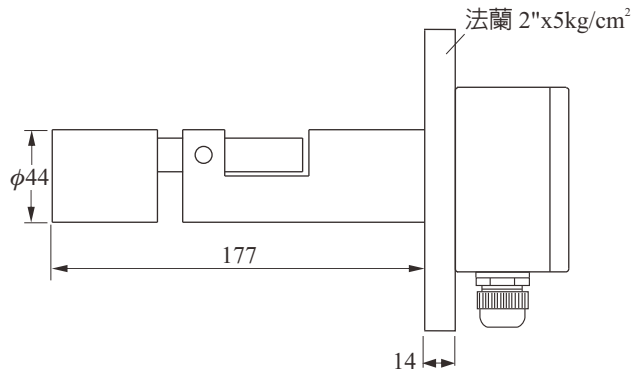

接線盒材質: PC  
接液材質: PP  
導線規格: PVC 3x0.75 mm<sup>2</sup>

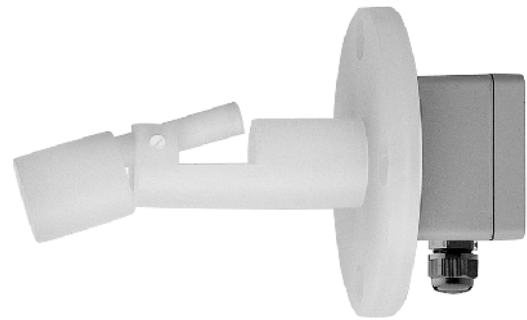

### ► FF81E (無接線盒)

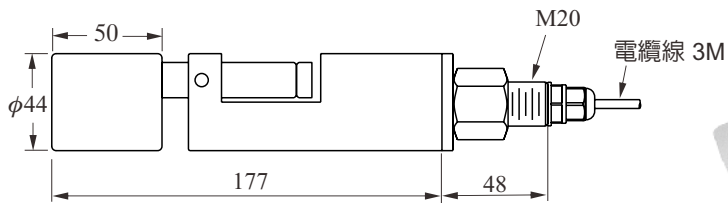

接續牙口: M20x P1.5  
接液材質: PP  
導線規格: PVC 3x0.75 mm<sup>2</sup>  
出線長度: 3M

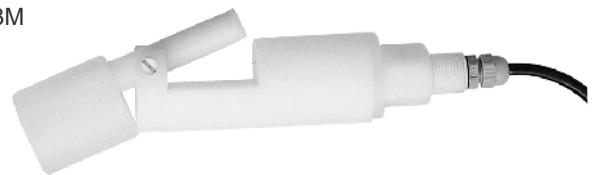

# 方法蘭一體型

## ► FF90CLO

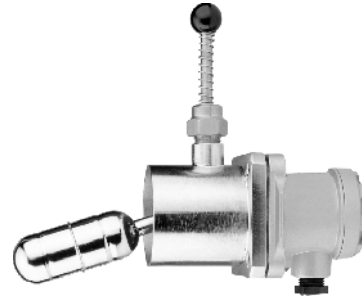
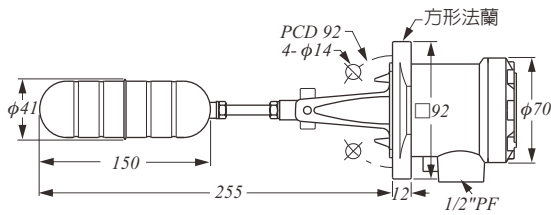

1. 接線盒: 鋁合金烤漆 (Ip65)
2. 適用比重: >0.65
3. 操作溫度: -20~100°C
4. 接點型式: SPDT (1C)
5. 接點容量: 5A/250VAC
6. 耐壓: 15kg/cm<sup>2</sup>
7. 接液材質: SUS304
8. 重量: 約 1.2 kg

### 開孔尺寸

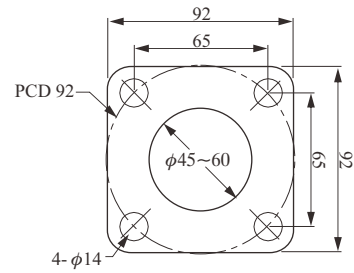

### 測試座(選購)

材質: SS41

將手動測試座與液位計焊接在一起，不須待液位下降即可定期檢查液位計是否正常動作。

### 檢查項目

液位開關的動作元件是否正常  
浮球是否正常上下移動

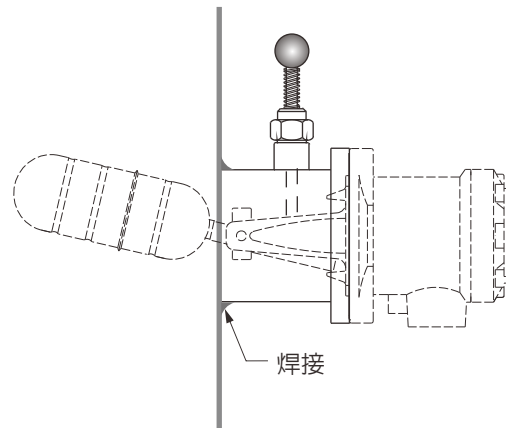
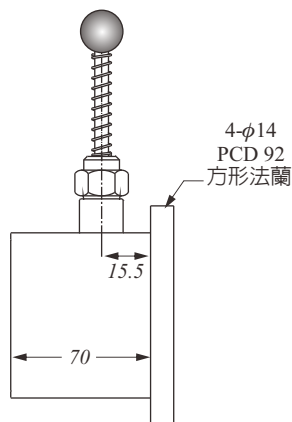
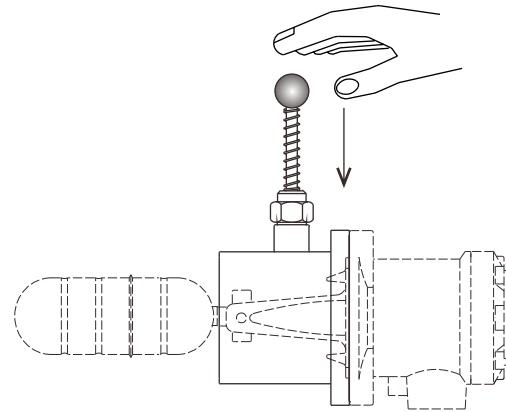

# 防爆型

▶ FF70CEQ

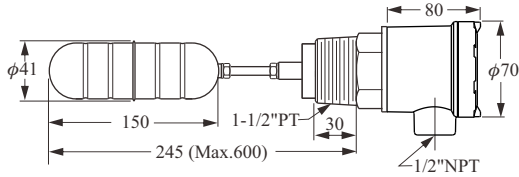

▶ FF70DFQ

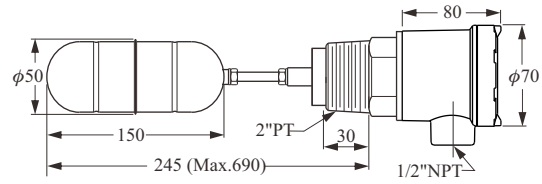

▶ FF71BHM

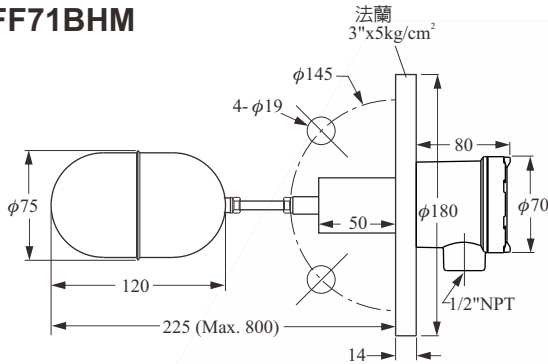

▶ FF71CEM

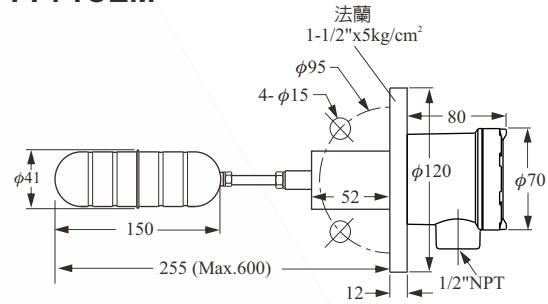

▶ FF71DFM

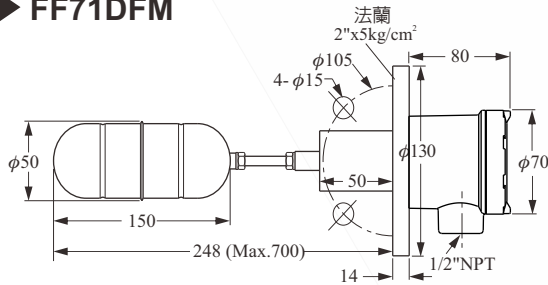

▶ FF74DFM

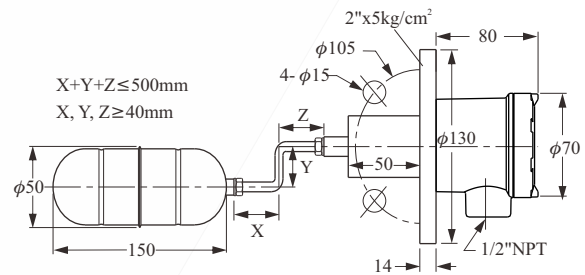

▶ FF73CLO

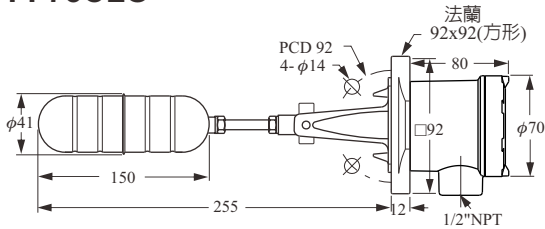

▶ FF75DFM

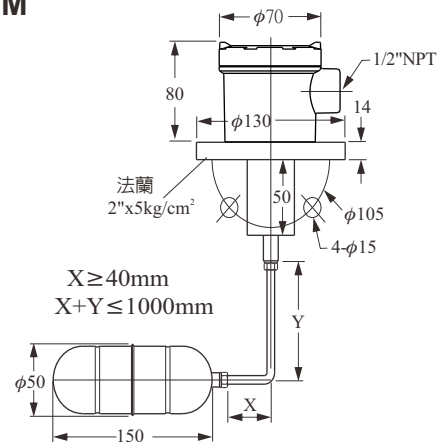

## 選購配件

### 防爆電纜接頭-Ex d IIC

材質: 橡膠墊圈---NBR  
 本體--- 銅合金(3/4"NPT)  
 銅鍍鎳(1/2"NPT)

HP415-A23100MH01(29-1104)

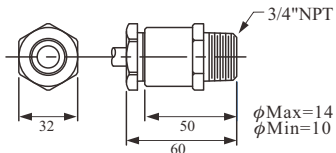

HP415-A23000MG01(29-1108)

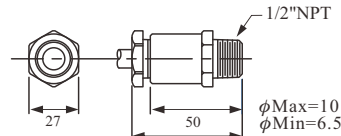

# 安裝注意事項

1. 用於酸鹼液中應選用塑膠材質
2. 接線盒入線口須朝下
3. 浮球及連桿必須全部進入桶槽
4. 安裝前應考慮液體比重
5. 安裝預留孔內徑必須大於浮球外徑 (參考第二頁)
6. 安裝時不可裝在靠近液體入水或排水口處

## 安裝實例

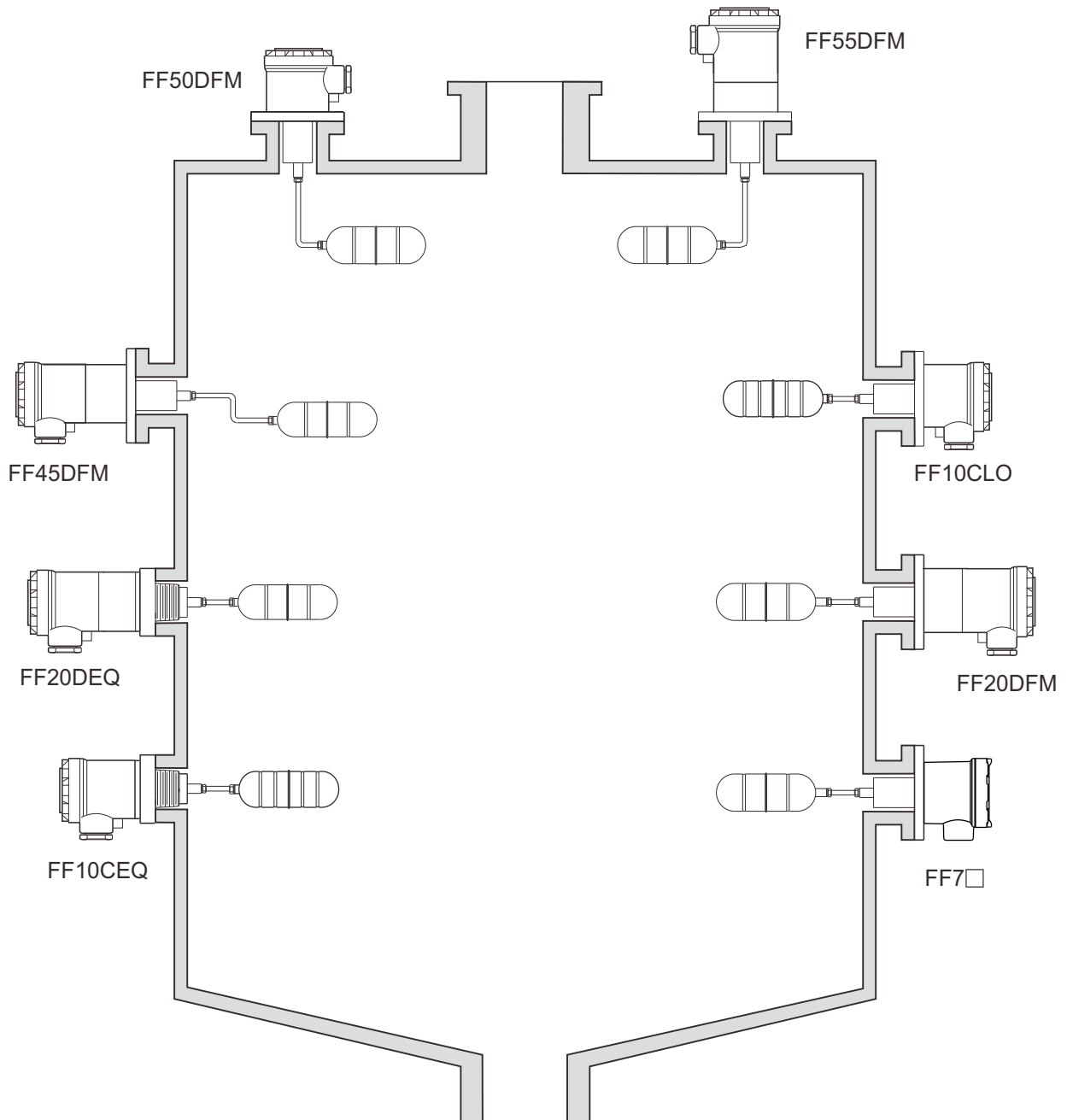

# 型號 / 訂購料號 對照表

型號	訂購料號
FF10BHM	FFX10000-A1HAKB540B
FF10CEM	FFX10000-A1HAKB140C
FF10CEQ	FFX10000-A1HAAB101C
FF10CLO	FFX10000-A1HAZ0000C
FF10DFM	FFX10000-A1HAKB240D
FF10DFQ	FFX10000-A1HAAB201D
FF15HEQ	FFX10000-A2ZAAB101F
FF12CEM	FFX10000-B1HAKB140C

型號	訂購料號
FF70CEQ	FFX1001C-A1MAAB101C
FF70CFM	FFX1001C-A1MAAB240C
FF70DFM	FFX1001C-A1MAAB240D
FF70DFQ	FFX1001C-A1MAAB201D
FF71BHM	FFX1001C-A1MAKB540B
FF71CEM	FFX1001C-A1MAKB140C
FF71CFM	FFX1001C-A1MAKB240C
FF71DFM	FFX1001C-A1MAKB240D
FF73CLO	FFX1001C-A6MAZ0000C
FF73GLO	FFX1001C-A6MAZ0000G
FF74DFM	FFX1001C-A5MAKB240D
FF75DFM	FFX1001C-A4MAKB240D

型號	訂購料號
FF20BHM	FFX10200-A1HAKB540B
FF20CEM	FFX10200-A1HAKB140C
FF20CEQ	FFX10200-A1HAAB101C
FF20DFM	FFX10200-A1HAKB240D
FF20DFQ	FFX10200-A1HAAB201D
FF20DLO	FFX10200-A1HAZ0000D

型號	訂購料號
FF90CLO	FFX10000-A6HAZ0000C
FF30A3Q	FFX10000-A70AAA901A
FF62DFM	FFX10800-A1HAKB240D
FF80EFM	FFX10000-A3GAKB240E18
FF81E	FFX10000-A30ABJ282E18

型號	訂購料號
FF40DFM	FFX10000-A5HAKB240D
FF45DFM	FFX10200-A5HAKB240D
FF50DFM	FFX10000-A4HAKB240D
FF55DFM	FFX10200-A4HAKB240D

# 訂購說明

FFX1 ⑤⑥⑦⑧⑨⑩⑪⑫⑬⑭⑮⑯⑰⑱⑲⑳㉑㉒㉓㉔

⑤⑥ 展型與重要功能

- 00: 標準型
- 01: 經濟型
- 02: 高溫型
- 08: 高溫1型

⑦⑧ 認證

- |                |              |               |
|----------------|--------------|---------------|
| 00: 無認證        | C0: ABS      | F1: LR+ATEX   |
| 1C: ATEX-Ex d  | E0: BV       | B7: DNV+NEPSI |
| 2C: IECEx-Ex d | F0: LR       | C7: ABS+NEPSI |
| 5C: TS-Ex d    | B1: DNV+ATEX | E7: BV+NEPSI  |
| 7C: NEPSI-Ex d | C1: ABS+ATEX | F7: LR+NEPSI  |
| B0: DNV        | E1: BV+ATEX  |               |

⑨⑩ 型式

- |             |               |
|-------------|---------------|
| A1: 標準型     | B1: 雙開關標準型    |
| A2: 迷你型     | B4: 雙開關頂裝型    |
| A3: 耐酸鹼型    | B5: 雙開關雙曲型    |
| A4: 頂裝型     | B6: 雙開關方法蘭一體型 |
| A5: 雙曲型     |               |
| A6: 方法蘭一體型  |               |
| A7: 超小型-單開關 |               |

⑪ 接線盒

- H: H型接線盒(鋁) · 單線出口1/2"PF-f 70\*70
- M: M型接線盒(限防爆認證選用)
- G: PC方型(限耐酸鹼型選用)
- O: 無
- U: 不鏽鋼 · M20(限迷你型選用)

接續尺寸

⑫⑬

- 法蘭選項
- AK: JIS-FF
  - AN: ANS-RF
  - AS: DIN-FF
  - AZ: 方法蘭 92x92

牙口選項

- AA: JIS
- AB: ISO
- AC: ANSI
- AD: DIN

⑭⑮

- 00:無須選擇
- A9: 1-1/4"
  - B1: 1-1/2"
  - B2: 2"
  - B4: 2-1/2"
  - B5: 3"
  - E1: DN40
  - E2: DN50
  - E3: DN65
  - E4: DN80
  - J2: M20

⑯⑰

- 00:無須選擇
- 01: 外牙PT
  - 03: 外牙PF
  - 05: 外牙BSP
  - 07: 外牙NPT
  - 13: 外牙GAS
  - 40: 5kg/cm<sup>2</sup>
  - 42: 10kg/cm<sup>2</sup>
  - 48: 150Lbs
  - 49: 300Lbs
  - 57: PN 10
  - 58: PN 16
  - 82: 外牙\_公制, P1.5

(接續下頁)

# 訂購說明

FFX1 05 06 07 08 - 09 10 11 12 13 14 15 16 17 18 19 20 21 22 23 24

⑱ 浮球型式

- A:  $\phi 32.5 \times 68$  , 15kg/cm<sup>2</sup> , 0.65S.G.
- B:  $\phi 75 \times 120$  , 10kg/cm<sup>2</sup> , 0.25S.G.
- C:  $\phi 41 \times 150$  , 15kg/cm<sup>2</sup> , 0.65S.G.
- D:  $\phi 50 \times 150$  , 30kg/cm<sup>2</sup> , 0.55S.G.
- E:  $\phi 44 \times 50$ (PP) , 5kg/cm<sup>2</sup> , 0.6S.G.
- F:  $\phi 41 \times 100$  , 15kg/cm<sup>2</sup> , 0.8S.G.
- G:  $\phi 41 \times 125$  , 15kg/cm<sup>2</sup> , 0.7S.G.

⑲ ⑳ 接液材質

- MA: SUS304
- MB: SUS316
- MC: SUS316L
- 18: PP

㉑ ㉒ ㉓ ㉔ 長度

編碼代號	長度範圍	備註
0000	標準長度	預設值依照型式
0250~0800	250~800mm	依浮球邊界與法蘭面 或螺紋根部定義長度
0270~1000	270~1000mm	
0155~0600	155~600mm	



# 全球據點

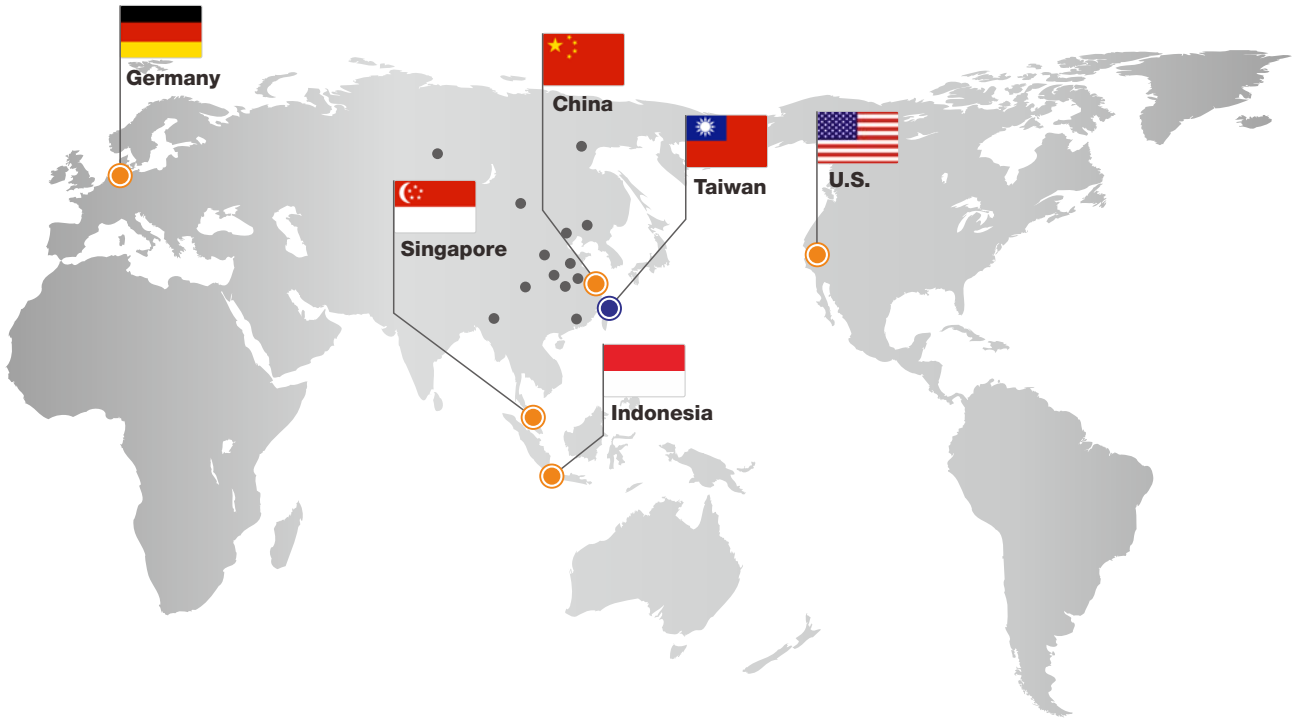

## ■ 總公司

- 台灣  
桓達科技股份有限公司 - 臺北總公司   
23678 新北市土城工業區自強街16號  
TEL: 886-2-2269-6789  
FAX: 886-2-2268-6682  
EMAIL: info@fine-tek.com

## ■ 亞太地區

- 中國  
上海凡宜科技電子有限公司 - 上海子公司   
201109 上海市閔行區都會路451號  
TEL: 86-21-6490-7260  
EMAIL: info.sh@fine-tek.com
- 新加坡  
FineTek Pte Ltd. - 新加坡子公司  
37 Kaki Bukit Place, Level 4 Singapore 416215  
TEL: 65-6452-6340  
EMAIL: info.sg@fine-tek.com
- 印尼  
PT. FineTek Automation Indonesia - 印尼子公司   
PERGUDANGAN TUNAS BITUNG  
JL. Raya Serang KM. 13,8, Blok C3 No. 12&15, Bitung Cikupa,  
Tangerang 15710  
TEL: +62 (021) 2958 1688  
EMAIL: info.id@fine-tek.com

## ■ 北美洲地區

- California, U.S.  
Aplus FineTek Sensor Inc. - 美國子公司  
355 S. Lemon Ave, Suite D  
Walnut, CA 91789  
TEL: 1 909 598 2488  
FAX: 1 909 598 3188  
EMAIL: info@aplusfine.com

## ■ 歐洲地區

- 德國  
FineTek GmbH - 德國子公司  
Bei den Kämpen 26  
21220 Seevetal-Ramelsloh, Germany  
TEL: +49-(0)4185-8083-12  
FAX: +49-(0)4185-8083-80  
EMAIL: info@fine-tek.de
- Müttec Instruments GmbH - 德國子公司   
Bei den Kämpen 26  
21220 Seevetal-Ramelsloh, Germany  
TEL: +49-(0)4185-8083-0  
FAX: +49-(0)4185-8083-80  
EMAIL: muetec@muetec.de



經銷商: