



ECP13

Display Pressure Gauge

Operation Manual



FinkTek Co., Ltd.

No.16, Tzuchiang St., Tucheng Industrial Park, New Taipei

City 23678 Tel: 886-2-22696789

Fax: 886-2-22686682

Website: <http://www.fine-tek.com>

E-mail: info@fine-tek.com

Contents

1. Reading Labels	1
2. Product Warranty	2
2.1 New Product Warranty.....	2
2.2 Repair Warranty	2
2.3 Service Network	3
3. Product Inspection	4
3.1 Check Content.....	4
3.2 Safety Inspection	4
4. Product Features	5
4.1 Product Features.....	5
4.2 Working Principles.....	5
4.3 Mechanical Drawing	5
4.4 Product Applications.....	5
5. Product Specifications	6
5.1 Product Applications.....	6
5.2 Panel	7
5.3 Dimension	7
5.4 Ordering Information	8
5.5 Wiring Instructions.....	8
6. Installation Instructions	10
6.1 Environmental Safety	10
7. Operating Instructions	10
7.1 Button Functions	10
7.2 Operation Flowchart.....	11
7.3 Command Description.....	13
7.4 Communication Command Description	14
8. Transportation And Storage	15
8.1 Transportation requirements	15
9. Maintenance	15
9.1 Daily Care	15
10. Error Message And Troubleshooting	15

1. Reading Labels

Thanks for purchasing FineTek's Product. This operation manual describes the product features, working principles, operation and maintenance methods. It makes the user fully understand how to use the product correctly, so as to prevent dangerous situations such as device damage or operator injury.

- Please read this operation manual completely and carefully before using the product.
- Please contact the company if this operation manual can't satisfy your demands.
- The content of the operation manual is updated based on the version upgrade, which will be uploaded to the website for the user to access.
- Please don't disassemble or repair the product on your own, as this will make you disqualified from availing of the warranty service. Please send the product back to the company for repair and calibration, or just contact the company.
- Explanation of warning signs:



Danger→ It indicates that wrong operation will cause death or major disasters.



Note→ It indicates that wrong operation will cause injury and device damage to some extent.



Electric shock→ It warns of possible electric shock.



Fire→ It warns of possible fire.



Prohibited→ It indicates the prohibited wrong behavior.

2. Product Warranty

2.1 New Product Warranty

- We don't charge for the inspection, part/s and repair for the product of the company that has a defect within 12 months from the delivery date and meets the warranty terms.
- If the product defect is not due to human error during its transportation, user may
- change to a new unit from the company within 7 days from delivery date.
- When the product needs to be sent back to the factory for repair, please send the whole set, and don't disassemble the parts. Moreover, please be sure it is completely packed to avoid damage and causing more loss and defect during the transportation.
- The warranty is not available for causes that fall under the following circumstances, for which the company shall charge for the inspection, part/s and repair according to the actual condition:
 - ◆ The product or its parts are beyond the warranty period.
 - ◆ Fault or damage is caused by not following the instruction and use environment described on the operation manual.
 - ◆ The product damage is caused by a force majeure factor (natural disasters, floods, fire, earthquakes, lightning, typhoon, etc.), human destruction (scratches, dropping, latch broken, tapping, cracks and punching), human error (using improper voltage, high-humidity, water leakage, stain, corrosion, loss, improper storage, etc.) and other abnormal factors.
 - ◆ The damage is caused by the customer or the 3rd party through the installation, addition, expansion, modification and repair of parts not authorized or certified by the company.
 - ◆ The volume label information is wrong or unclear, so the product serial number can't be confirmed.

2.2 Repair Warranty

A **6-month** warranty service is provided for the repaired part of the product, during which the same product can be repaired free of charge in case of the same fault.

2.3 Service Network

Company	Address	Telephon	Fax
Taipei Headquarters (Taiwan)	No.16, Tzuchiang St., Tucheng Industrial Park, New Taipei City 23678	+886 2 2269 6789	+886 2 2268 6682
Taichung Sales office (Taiwan)		+886 4 2465 2820	+886 4 2463 9926
Kaohsiung Sales office (Taiwan)		+886 7 333 6968	+886 7 536 8758
Fine automation Co., Ltd. (China)	No. 451, Duhui Road, Zhuanqiao Township, Minhang District, Shanghai City 201109	+86 021 64907260	+86 021 6490 7276
Aplus FineTek Sensor Inc. (America)	355 S. Lemon Ave, Suite D, Walnut, CA 91789	1 909 598 2488	1 909 598 3188
FineTek Pte Ltd. (Singapore Branch)	37 Kaki Bukit Place, Level 4 Singapore 416215	+65 6452 6340	+65 6734 1878
FineTek GmbH (Germany Branch)	Bei den Kämpen 26 21220 Seevetal-Ramelsloh, Germany	+49 (0) 4185 8083 12	+49 (0) 4185 8083 80
FineTek Co., Ltd. (Indonesia Branch)	PERGUDANGAN TUNAS BITUNG JL. Raya Serang KM. 13,8, Blok C3 No. 12&15, Bitung Cikupa, Tangerang 15710	+62 (21) 2923 1688	+62 (21) 2923 1988

3. Product Inspection

3.1 Check Content

- Sensor x 1
- Cable x 1
- Operation manual x 1

3.2 Safety Inspection

- Please check whether the external package is deformed or damaged. Please remember to take a picture for evidence for compensation later.
- After unpacking, please check whether the content is deformed or damaged, or has any quality problem. Please remember to take a picture for evidence for compensation later.
- After unpacking, please check whether the content is consistent with the ordering info, and whether the quantity is right.
- Please contact the company within 7 days if any of the above situations occur (attach the picture together with your complaint). Otherwise, we won't compensate for, change or repair the product defect.

4. Product Features

4.1 Product Features

- Dual-color LED and red-text alarm displays
- Analog 4 – 20 mA output that allows continuous detection of pressure values
- Anti-corrosion structural design that is suitable for minimally corrosive solution
- Quick release mount to facilitate calibration and replacement
- Dual NPN/PNP output that makes pressure control quicker and more convenient
- IO-Link compatibility to make system integration easier

4.2 Working Principles

With the piezoresistive pressure sensor, as soon as changes in environmental pressure are detected, the thin film deformation on the pressure sensor changes too, and the piezoresistive material on the thin film experiences deformation accordingly. The resistance changes as such as well. Such resistance change, once read and processed through the Wheatstone bridge and the amplifier circuit, can be used to measure the size of pressure.

4.3 Mechanical Drawing

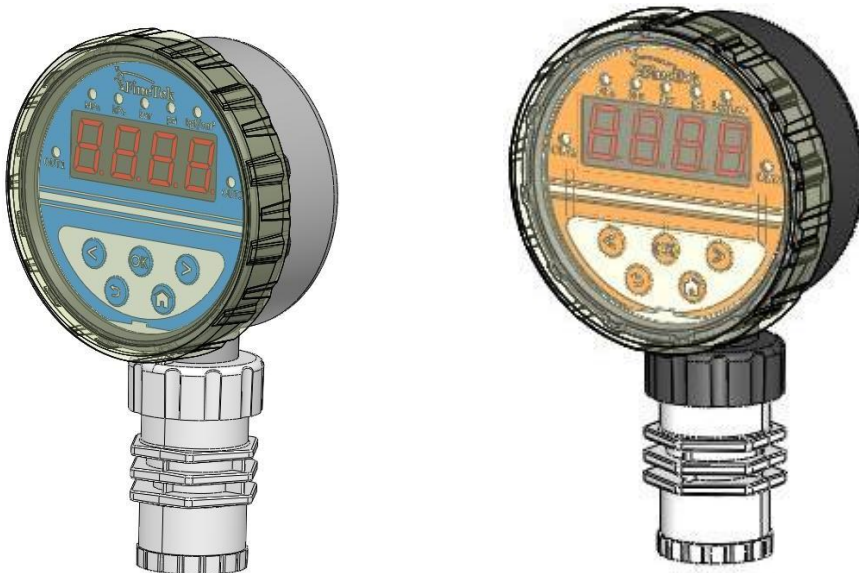

4.4 Product Applications

This product is applied to a modularized pressure meter where air, water, and solution with a pH value are used.

5. Product Specifications

5.1 Product Applications

Power supply	DC 12~36V
Power consumption	<50mA (@24V unloaded)
Operating temperature	-25 to 60°C
Working medium	Liquid/Slight corrosive liquid/air
Material	Housing: PP, Diaphragm: Ceramic
Connection specification	1/2"
Accuracy	±1.0% F.S.
Temperature coefficient	±0.1%F.S./ °C (25°C as the baseline)
NPN/PNP output current	Maximum pressure tolerance of 30 V/100 mA and breakover residual voltage of < 1.5 V
NPN/PNP protective current	125mA
NPN/PNP short-circuit protection	Yes
Delay time	1.5 ms, 20 ms, 100 ms, 500 ms, 1,000 ms, 2,000 ms, 5,000 ms
Current output	4~20mA Max. Load resistance When the power voltage is 12V: 300Ω When the power voltage is 24V: 500Ω Linearity: ±1%F.S. Accuracy : ±2.5%F.S. (ambient temperature of 25 ± 3°C)
Display unit	MPa, kPa, kgf / cm ² , bar, psi
Number of digits displayed	Red/Green LED and 4 (7 segments)
Action indicator	It is lit when the output is ON OUT1 and OUT2: Red

5.2 Panel

The panel includes five keys for parameter adjustment, two output indicators (OUT1/OUT2), and supports five selectable pressure units for display



5.3 Dimension

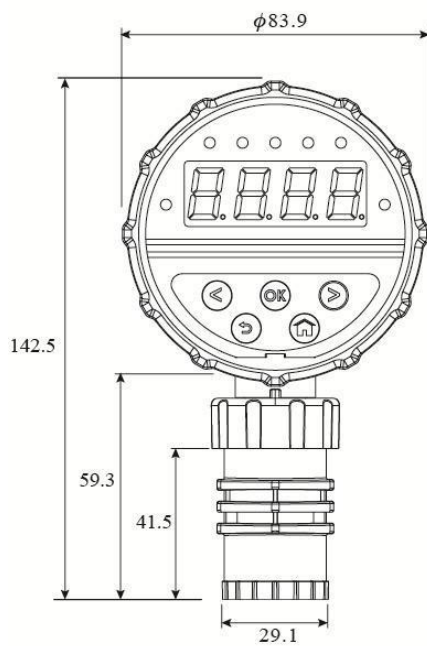

5.4 Ordering Information

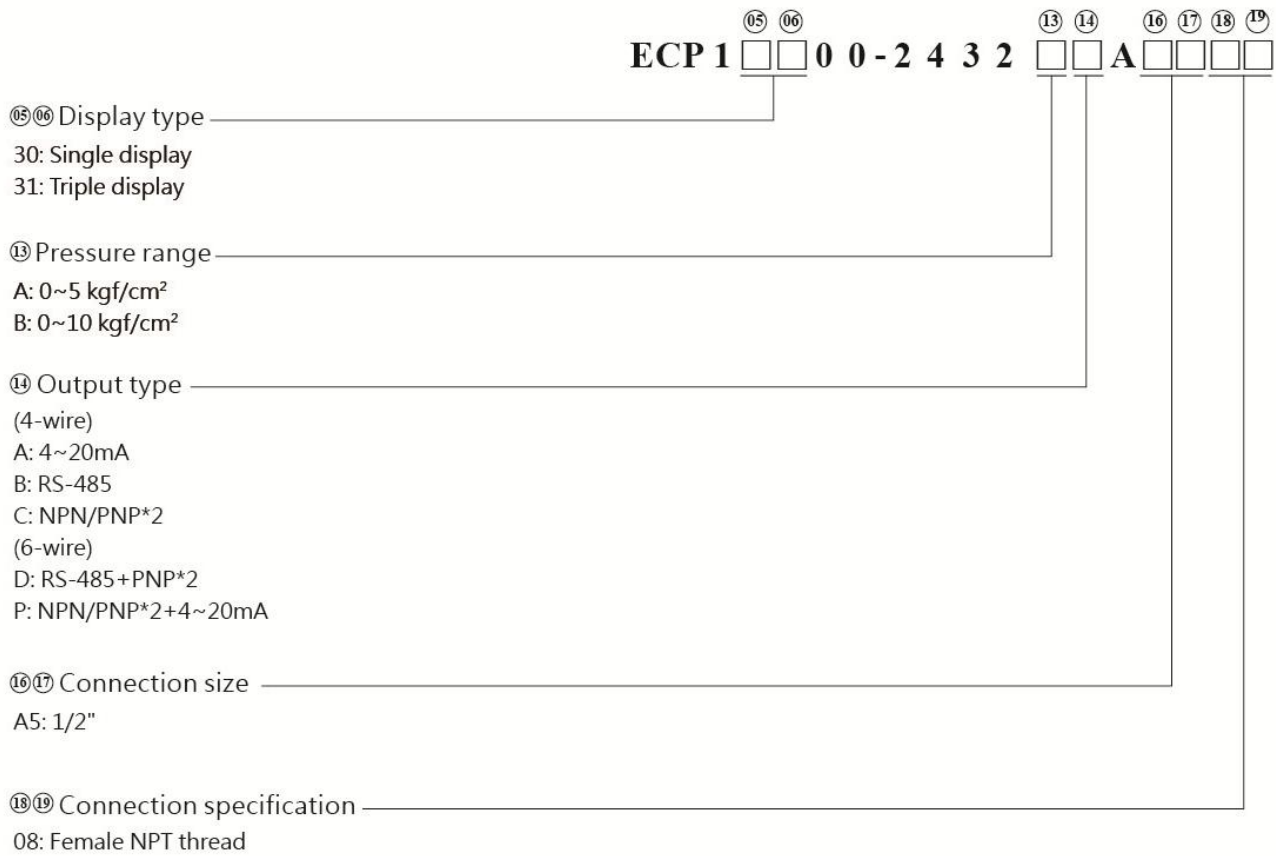

5.5 Wiring Instructions

(4-core) The ECP is connected via a 4-core M12 cable connector. Information on OUT1/OUT2 connection:

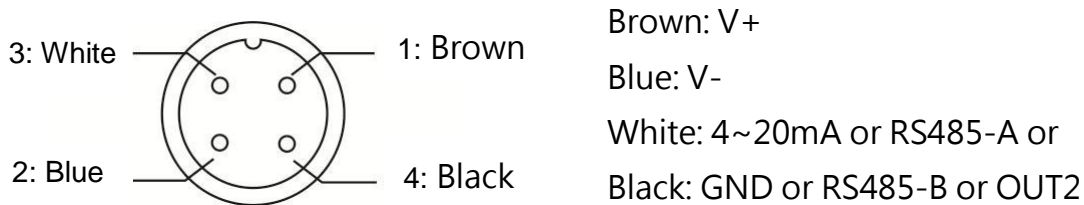

(6-core) The ECP is connected via a 6-core M12 cable connector.



(4-core) OUT1/OUT2 Wiring Description:

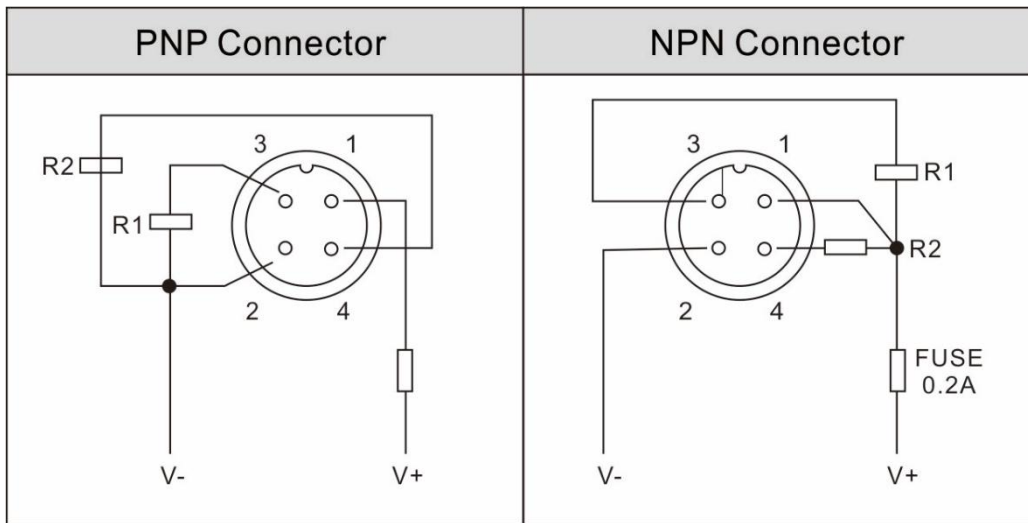

(6-core) OUT1/OUT2 Wiring Description:

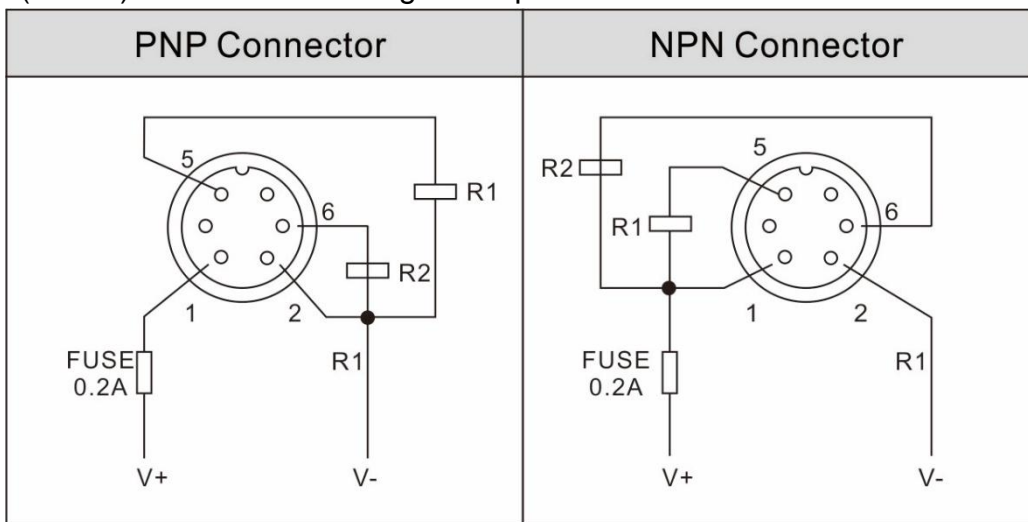

6. Installation Instructions

6.1 Environmental Safety

- Operating temperature: -25°C ~ 60°C
- Power supply: 12 VDC ~ 36VDC
- Output load current: Max, 50 mA

7. Operating Instructions

7.1 Button Functions

Quick key:

Press and hold (1 s)  When the displayed pressure is below 0.3, set the low-point cutoff to the current pressure value

Press and hold (1 s)  Unlock in lock mode

Press  In lock mode, cycle through pressure units

Press  Enter the basic settings menu

Press  From the display screen, enter the alarm setting menu

General Operation:

Press  Enter next menu level / confirm input

Press  Switch within the same menu level

Press  Increase value

Press  Return to the previous menu (without saving changes)

Press  Exit menus quickly and return to the display screen (when not in display mode)

7.2 Operation Flowchart

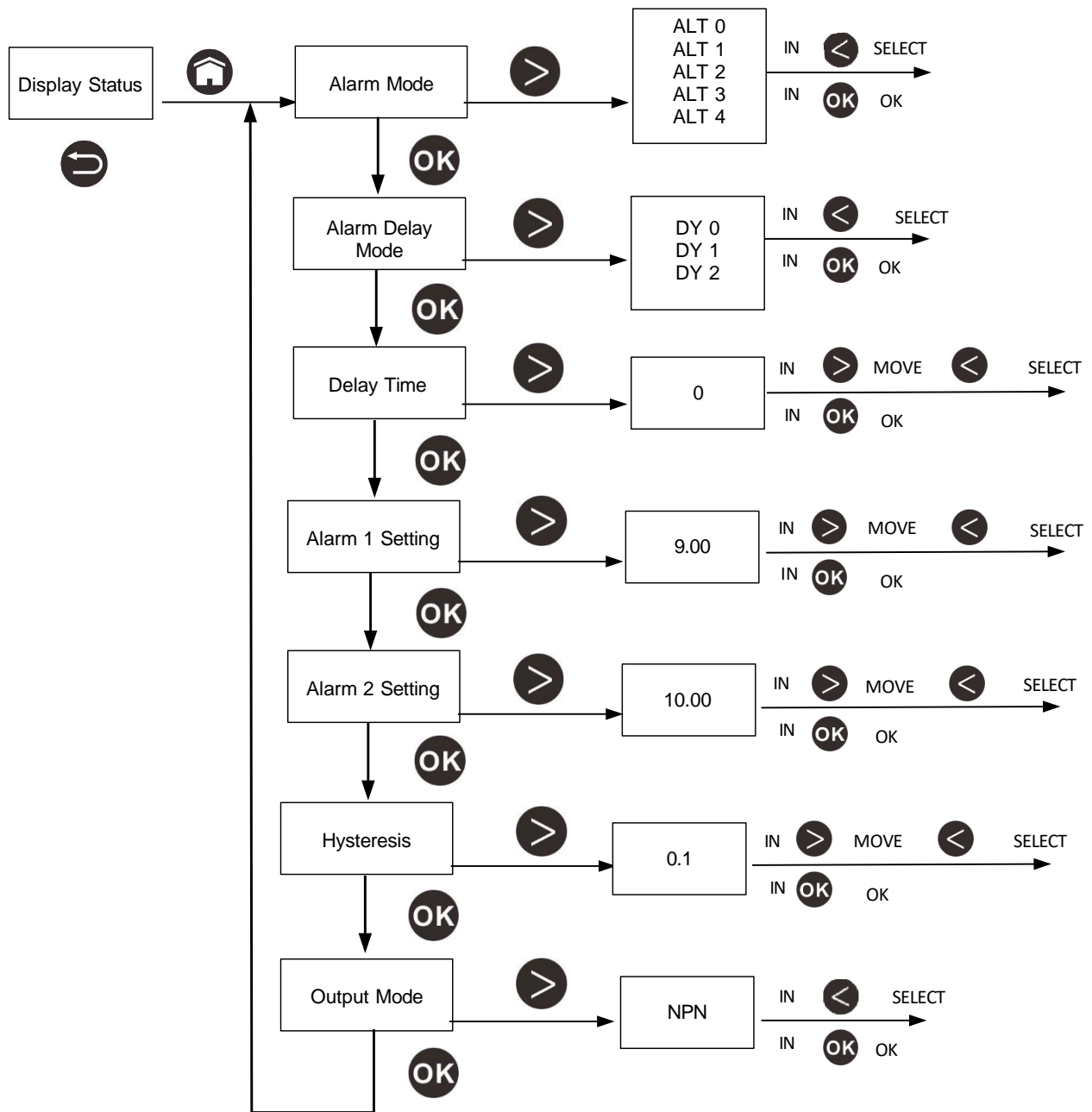

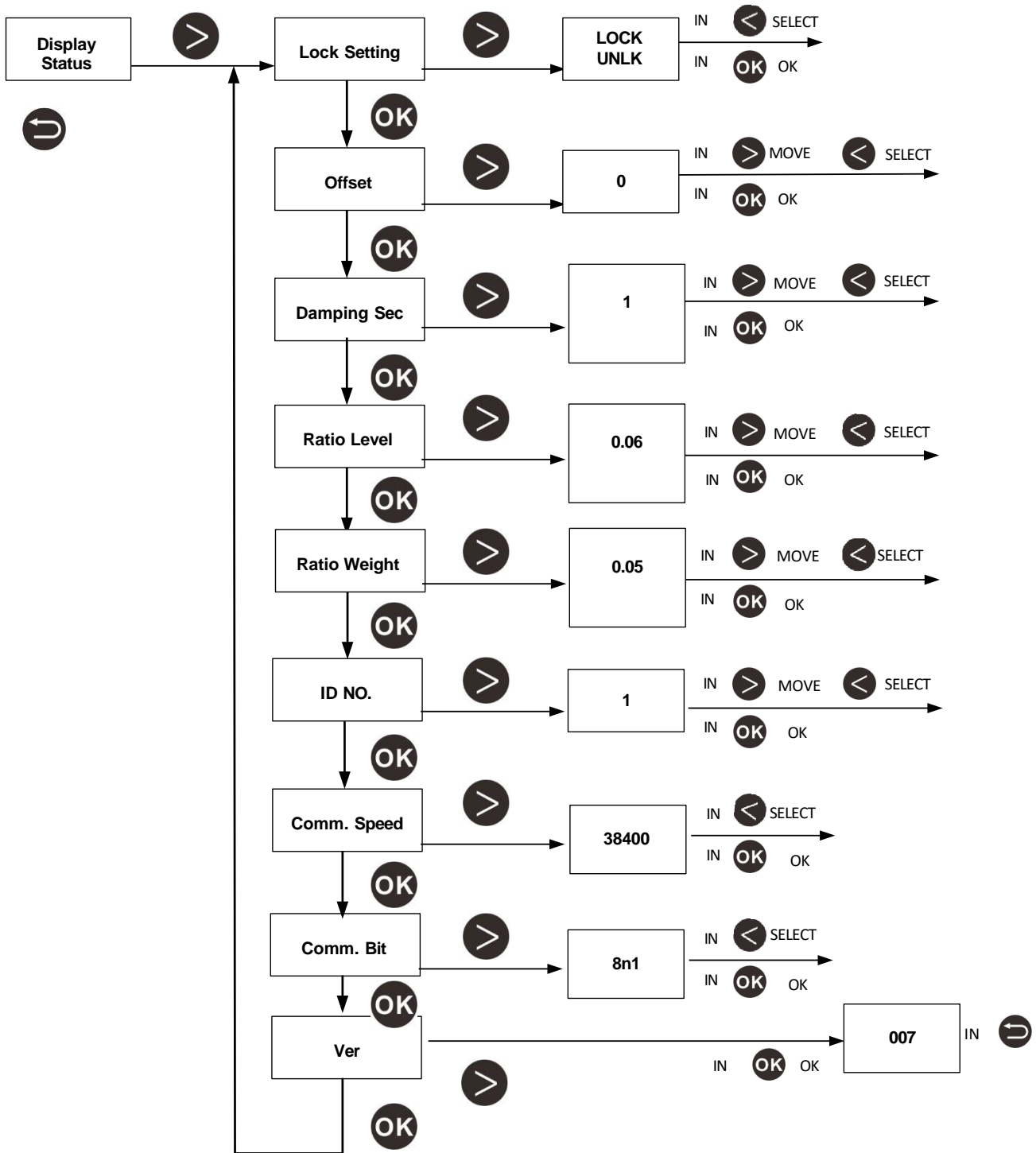

7.3 Command Description

Alt 0: Alarm Disabled

- No alarm output will be generated.

Alt 1: Basic Alarm Mode

- When $CV \geq AL1 \rightarrow R1$ ON
- When $CV < (AL1 - H) \rightarrow R1$ OFF
- When $CV \leq AL2 \rightarrow R2$ ON
- When $CV > (AL2 + H) \rightarrow R2$ OFF

This is the most commonly used standard alarm mode.

The alarm is triggered immediately when the measured value exceeds the setpoint, and is released only after the value falls below the setpoint minus the hysteresis (H), preventing frequent switching.

Alt 2: Delayed Trigger Alarm

- When $CV < (AL1 - H) \rightarrow R1$ ON
- When $CV \geq AL1 \rightarrow R1$ OFF
- When $CV > (AL2 + H) \rightarrow R2$ ON
- When $CV \leq AL2 \rightarrow R2$ OFF

The alarm is triggered only when the measured value clearly exceeds the setpoint (including hysteresis H), reducing false alarms caused by minor fluctuations.

Suitable for applications requiring stable judgment.

Alt 3: Deviation Alarm (Both-Side)

- When $CV < (AL1 - H) \rightarrow R1$ ON
- When $CV \geq AL1 \rightarrow R1$ OFF
- When $CV < (AL2 - H) \rightarrow R2$ ON
- When $CV \geq AL2 \rightarrow R2$ OFF

The setpoint is treated as a reference center value.

An alarm is triggered when the measured value deviates excessively above or below the setpoint.

Suitable for applications requiring the value to remain within a defined range.

Alt 4: Deviation Alarm with Hysteresis

- When $CV \geq AL1 \rightarrow R1$ ON
- When $CV < (AL1 - H) \rightarrow R1$ OFF
- When $CV \geq AL2 \rightarrow R2$ ON
- When $CV < (AL2 - H) \rightarrow R2$ OFF

Similar to Alt 3, but with added hysteresis to further prevent repeated alarm activation.

Suitable for applications with large fluctuations where stable range monitoring is required.

7.4 Communication Command Description

The ECP13 display pressure gauge supports the industrial Modbus communication protocol.

Modbus communication uses RTU mode with half-duplex transmission.

The default communication settings are as follows:38400 (bps) 、1 Start Bit 、8 Data Bits 、No Parity 、1 Stop Bit 。

	Address(Hex)	Address(Dec)	Parameter	Data Type	Definition	R/W
1	0x1020	4128	UINT16	PFC_PRESSURE_VOLTAGE,	Pressure value (fixed unit: kgf/cm ²)	Read only
2	0x1022	4130	UINT16	PFC_DISPLAY_PRESSURE_VALUE,	Current displayed pressure (based on the selected unit)	Read only
3	0x1024	4132	UINT16	PFC_TEMPERATURE_VOLTAGE,	Temperature value	Read only
4	0x1029	4137	FLOAT32	PFC_OUTPUT_CURRENT,	Real-time output current (mA)	Read only
5	0x102A	4138				
6	0x1042	4162	UINT16	PFC_OUT1_TYPE,	output 1 type (0:PNP/1:NPN)	Read /Write
7	0x1043	4163	UINT16	PFC_OUT2_TYPE,	output 2 type (0:PNP/1:NPN)	Read /Write
8	0x1044	4164	FLOAT32	PFC_OUT1_POINT,	Output 1 switching pressure setpoint (kgf/cm ²)	Read /Write
9	0x1045	4165				Read /Write
10	0x1048	4168	FLOAT32	PFC_OUT2_POINT,	Output 2 switching pressure setpoint (kgf/cm ²)	Read /Write
11	0x1049	4169				Read /Write
12	0x104C	4172	UINT16	PFC_DISPLAY_UNIT,	Pressure display unit setting 0:kgf/cm ² 1:psi 2:bar 3:kpa 4:Mpa 5:°C	Read /Write
13	0x1050	4176	UINT16	PFC_OUT1_DELAY,	OUT1 output delay time	Read /Write
14	0x1051	4177	UINT16	PFC_OUT2_DELAY	OUT2 output delay time	Read /Write
15	0x1052	4178	UINT16	PFC_MODBUS_ID	Modbus ID setting	Read /Write
16	0x1053	4179	UINT16	PFC_MODBUS_BAUDRATE	0:9600 1:19200 2:38400 3:57600	Read /Write
17	0x1054	4180	UINT16	PFC_MODBUS_BITS_MODE,	0:"8_NONE_One" 1:"8_Odd_One" 2:"8_Even_One" 3:"8_NONE_Two"	Read /Write
18	0x107A	4218	UINT16	PFC_ENGR_SPAN,	0:5kg 1:10kg 2:20kg	Read /Write
19	0x107B	4219	UINT16	PFC_ENGR_HYS	0.1kgf/cm ²	Read /Write
20	0x107C	4220	UINT16	PFC_ENGR_ALT	0:ALT0 1:ALT1 2:ALT2 3:ALT3 4:ALT4	Read /Write

8. Transportation And Storage

8.1 Transportation requirements

To prevent the ECP Pressure Guage from damage during the transportation, please keep the packaging condition as how it was when it was shipped from the factory before arriving at the installation site. The storage conditions should meet the following:

- Appropriate rainproof and damp-proof treatment must be conducted .
- Vibration must be reduced and collision with other objects must be prevented during its transportation.
- The storage temperature must be in the range of -25 ~ 60°C
- The humidity should be lower than 80%

9. Maintenance

9.1 Daily Care

Periodically check the pressure sensing port to see if it is clogged by foreign matters or damaged; if it is seriously clogged, clean it. If it is damaged, replace the equipment.

When equipment is removed and before it is re-installed, confirm carefully if pressure is released from pressurized pipes to avoid leakage of liquids from the pipes.

The disposal of equipment shall be based on local national regulations in an environmentally friendly way.

In the case of return, please make sure that the product is not contaminated, particularly by hazardous or poisonous substances. For the transport, suitable packaging is required to avoid damaging the equipment.

10. Error Message And Troubleshooting

Abnormality	Possible causes	Solution
No display	No power supply	Check the power line and repair it.
No display	Failure to meet product specification requirements in terms of power	Confirm that power supply is 12–30 Vdc and correct it
No response with On/Off	Abnormal wiring	Check wiring, terminal pin, and correct it
No response with On/Off	Insufficient power supply to drive output	Check power supply (it has to be >12Vdc) and correct it
The switch signal is not stable and works intermittently.	Make sure the wiring of the switch signal and power cable terminals does not become lose or come off.	Confirm the wire pin again to ensure the correction connection of the lines.