



EPD36

Sanitary Electromagnetic Flow Meter

Operation Manual



FineTek Co., Ltd.

No.16, Tzuchiang St., Tucheng Industrial Park, New Taipei City 23678

Tel: 886-2-22696789

Fax: 886-2-22686682

Website: <http://www.fine-tek.com>

E-mail: info@fine-tek.com

Contents

1. Reading Labels	1
2. Product Warranty	2
2.1 New Product Warranty	2
2.2 Repair Warranty	2
2.3 Service Network	3
3. Product Inspection	4
3.1 Check Content.....	4
3.2 Safety Inspection.....	4
4. Summary.....	4
5. Product Features	5
6. Applicable Scope	5
7. Environmental Condition	5
8. Working Principles	6
9. Technical Performance.....	7
9.1 Execution Standards	7
9.2 Basic Parameters and Performance Indicators	7
9.2.2 Recommended Flow Range for Tube Diameters	8
9.2.3 Lining Material	8
9.2.4 Electrode Material	8
9.2.5 Housing Protection Rating(IP)	8
10. Appearance and Dimension.....	9
10.1 Tri-Clmp Type.....	9
10.1.1 Tri-Clamp.....	9
11. Installation.....	10
11.1 Conditions required to guarantee the measurement accuracy of the electromagnetic flow meter:	10
11.2 Safety Measures	10
11.3 Inspection before Installation.....	10
11.4 Handling	11
11.5 Correct Installation	11
11.6 Notes for Installation on the Pipe.....	13
11.7 Grounding Requirements	14
11.8 Changing the Direction of the Transmitter Box.....	14
12. Wiring and Using	15
12.1 Wiring.....	15
12.1.1 Notes for Wiring.....	15
12.1.2 Open the external cover on the rear side, you will see the wiring terminal as shown below.	15

13. Inspection before Power-On	16
14. Parameter Functions	17
14.1 Procedure for Menu Setting.....	17
14.1.1 Functions of the Display Interface	17
14.1.2 Button Functions in Parameter Setting Status:.....	17
14.2 Various Parameter Setting Ranges	18
14.3 System record illustration	20
15. Ordering Information	23
16. Transportation and Storage	24
17. Fault Inspection and Repair	25
18. MODBUS Communication Protocol.....	28

1. Reading Labels

Thanks for purchasing FineTek's Product. This operation manual describes the product features, working principles, operation and maintenance methods. It makes the user fully understand how to use the product correctly, so as to prevent dangerous situations such as device damage or operator injury.

- Please read this operation manual completely and carefully before using the product.
- Please contact the company if this operation manual can't satisfy your demands.
- The content of the operation manual is updated based on the version upgrade, which will be uploaded to the website for the user to access.
- Please don't disassemble or repair the product on your own, as this will make you disqualified from availing of the warranty service. Please send the product back to the company for repair and calibration, or just contact the company.
- Explanation of warning signs:



Danger→ It indicates that wrong operation will cause death or major disasters.



Note→ It indicates that wrong operation will cause injury and device damage to some extent.



Electric shock→ It warns of possible electric shock.



Fire→ It warns of possible fire.



Prohibited→ It indicates the prohibited wrong behavior.

2. Product Warranty

2.1 New Product Warranty

- We don't charge for the inspection, part/s and repair for the product of the company that has a defect within 12 months from the delivery date and meets the warranty terms.
- If the product defect is not due to human error during its transportation, user may change to a new unit from the company within 7 days from delivery date.
- When the product needs to be sent back to the factory for repair, please send the whole set, and don't disassemble the parts. Moreover, please be sure it is completely packed to avoid damage and causing more loss and defect during the transportation.
- The warranty is not available for causes that fall under the following circumstances, for which the company shall charge for the inspection, part/s and repair according to the actual condition:
 - The product or its parts are beyond the warranty period.
 - Fault or damage is caused by not following the instruction and use environment described on the operation manual.
 - The product damage is caused by a force majeure factor (natural disasters, floods, fire, earthquakes, lightning, typhoon, etc.), human destruction (scratches, dropping, latch broken, tapping, cracks and punching), human error (using improper voltage, high-humidity, water leakage, stain, corrosion, loss, improper storage, etc.) and other abnormal factors.
 - The damage is caused by the customer or the 3rd party through the installation, addition, expansion, modification and repair of parts not authorized or certified by the company.
 - The volume label information is wrong or unclear, so the product serial number can't be confirmed.

2.2 Repair Warranty

A **6-month** warranty service is provided for the repaired part of the product, during which the same product can be repaired free of charge in case of the same fault.

2.3 Service Network

Company	Address	Telephon	Fax
Taipei Headquarters (Taiwan)		+886 2 2269 6789	+886 2 2268 6682
Taichung Sales office (Taiwan)		+886 4 2465 2820	+886 4 2463 9926
Kaohsiung Sales office (Taiwan)		+886 7 333 6968	+886 7 536 8758
Fine automation Co., Ltd. (China)	No. 451, Duhui Road, Zhuanqiao Township, Minhang District, Shanghai City 201109	+86 021 64907260	+86 021 6490 7276
Aplus FineTek Sensor Inc. (America)	355 S. Lemon Ave, Suite D, Walnut, CA 91789	1 909 598 2488	1 909 598 3188
FineTek Pte Ltd. (Singapore Branch)	37 Kaki Bukit Place, Level 4 Singapore 416215	+65 6452-6340	+65 6734-1878
FineTek GmbH (Germany Branch)	Bei den Kämpen 26 21220 Seevetal-Ramelsloh, Germany	+49 (0) 4185 8083 0	+49 (0) 4185 8083 80
FineTek Co., Ltd. (Indonesia Branch)	PERGUDANGAN TUNAS BITUNG JL. Raya Serang KM. 13,8, Blok C3 No. 12&15, Bitung Cikupa, Tangerang 15710	+62 021-2958-1688	

3. Product Inspection

3.1 Check Content

- 1 flow meter
- 1 operation manual
- 1 product inspection sheet

3.2 Safety Inspection

- Please check whether the external package is deformed or damaged. Please remember to take a picture for evidence for compensation later.
- After unpacking, please check whether the content is deformed or damaged, or has any quality problem. Please remember to take a picture for evidence for compensation later.
- After unpacking, please check whether the content is consistent with the ordering info, and whether the quantity is right.
- Please contact the company within 7 days if any of the above situations occur (attach the picture together with your complaint). Otherwise, we won't compensate for, change or repair the product defect.

4. Summary

The company's electromagnetic flow meter adopts coil excitation, which is more stable than the traditional magnetism generation. After strict vibration and anti-noise test, it can work stably and is highly tolerant of complex environments in the industrial field, which also has a longer life span in practical application.

The electromagnetic flow meter has kept on evolving since its initial development, which is widely applied in monitoring various industrial fluid pipes, including power generation, water treatment, food, medication, shipping, dyeing & finishing, and semi-conductor process industries. With its simple working principle, the electromagnetic flow meter is widely applicable in various environments as long as the correct model is selected to match the fluid properties.

5. Product Features

- The measurement results is not affected by the change of liquid density, viscosity, temperature, pressure and conductivity.
- There are only two measurement points in the measuring tube without baffle and movable parts, so it won't cause pressure loss and jam.
- It can test the flow for the conducting fluid and the fluidic containing some solid granules.
- The straight tube section required for the installation just needs the upstream front 5D and downstream 2D of the flow meter without complicated pipeline design.
- The measurement turndown ratio can reach 1:100, which can achieve high accuracy especially for measuring small flow.
- It has a self-diagnosis function, which can automatically detect the excited signal, whether the measuring tube is empty and whether the electrode is stained or damaged.
- The material of lining is PFA
- The maximum fluidic temperature permitted can reach 150°C
- The flow converter setting is simple, with powerful functionality.
- Available for records for parameter modifications, boot/ shut down device (Option)
- Authority management is available in Menu (Option)

6. Applicable Scope

- Conductivity: > 5 μ S/cm
- Fluid properties: Pure liquid and fluidic containing some solid granules.
- Application industries: Power generation, water treatment, food, medication, shipping, dying & finishing, and semi-conductor process

7. Environmental Condition

- Ambient environment: -40°C ~ 70°C
- Relative humidity: 5% ~ 95% of RH, without condensing water
- Atmospheric pressure: 86 ~ 106 KPa
- Power supply: DC24V

8. Working Principles

The working principle of the electromagnetic unit is based on the Faraday law of electromagnetic induction. When the conductor moves in the magnetic field, it will generate induced EMF on both sides of the conductor in the orthogonal direction of the magnetic field direction and the motion direction. The EMF is directly proportional to the motion speed of the conductor and the magnetic induction intensity.

As shown in <Figure 1>, the conducting fluidic passes through the insulating tube with the internal diameter of $D(m)$ at the average flowing speed $V(m/s)$ that is equipped with a pair of measuring electrodes. Moreover, the tube is in a magnetic field with uniform magnetic induction intensity of $B (T)$. In this case, the electrodes will induce the EMF (E) at the orthogonal direction of the magnetic field and the flowing direction. According to the law of electromagnetic induction, E can be written as Equation (1):

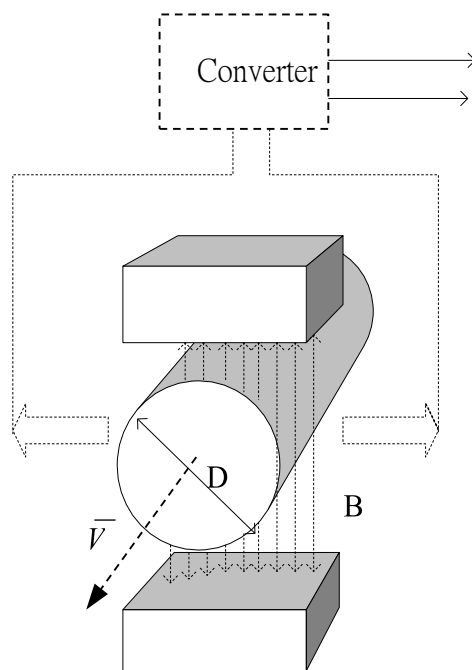

<Figure 1>

$$E = kB \cdot D \cdot V \text{ (v)} \dots\dots\dots (1)$$

Wherein, k is the proportional coefficient.

The volume flow can be written as

$$q_v = \frac{\pi D^2}{4} V \text{ (m}^3/s \text{)} \dots\dots\dots (2)$$

From Equation (1) and (2), we can get:

$$q_v = \frac{\pi D}{4k} \frac{E}{B} \text{ (m}^3/s \text{)} \dots\dots\dots (3)$$

Thus, EMF can be represented as:

$$E = \frac{4kB}{\pi D} q_v \text{ (V)} \dots\dots\dots (4)$$

When B is a constant in Equation(3)

$\frac{\pi D}{4k B} = A$, Equation(3) can be modified as:

$$q_v = AE \text{ (m}^3/s \text{)} \dots\dots\dots (5)$$

It can be concluded that the flow q_v is directly proportional to the EMF E .

9. Technical Performance

9.1 Execution Standards

IEC 60068-2-3	EN 61326-1:2013
IEC 61326-1	EN 55011:2009/A:2010
IEC 60092-504	ISO 4064-1
JIS B2220	JIS B7554-1997
ANSI B16.5	DIN 25 Series

9.2 Basic Parameters and Performance Indicators

9.2.1 Technical Specification Table

Item	EPD36 Standard type
Display	LCM 128* 64 pixel backlit type
Buttons	Tri-button operation
Communication interface	RS-485 (Modbus)
Accuracy	±0.5% of reading@1m/s(0.2% optional)
Medium temperature	-20~150°C(PFA Lining)
Ambien temperature	-40~70°C*
Fluidic conductivity	>5uS/cm
Measuring scope	0.1m/s~10m/s
Current output accuracy	0.1% of Pulse Output Accuracy Temperature coefficient (100ppm/°C)
Operating pressure	10 kg/cm ²
Current output mode	Proactive
Analog output	4~20 mA
Maximum load of current output	<700 Ω
Alarming current	3.6 mA or 22 mA
Frequency output scope	2~8 KHz
Pulse width	Automatic (pulse width 50%)
Pulse mode	Isolated NPN Transistor output 32vdc/200mA
Time constant	1~100 s
Control output (DO)	solated NPN Transistor output 32vdc/200mA; 2-CH
Control input (DI)	Dry contact ON< 200 Ω ; 1,000 Ω< OFF ; 1-CH
Data logger(Optional)	500 items. With calendar (Internal battery: Lift time>6 month)
Baud rate	1200~57600 bps
Protection rating	IP67/NEMA 4X
Enclosure material	Aluminum alloy
Input power	DC 24V
Power consumption	<10 W
Wire inlet specification	1/2" NPT
Excitation mode	Pulse DC
Vibration regulation	MIL-STD-202G-201A:2002
EMC regulation	IEC/EN 61326-1 Class A table 2

* It can't display when LCM is lower than -20°C.

9.2.2 Recommended Flow Range for Tube Diameters

Pipe diameter (mm)	Flow range (m ³ /h)	
	Flowing speed 0.1~1.0 m/s	Flowing speed 1.0~10 m/s
15	0.06~0.64	0.64~6.4
25	0.17~1.77	1.77~17.7
40	0.45~4.5	4.5~45.2
50	0.71~7.1	7.1~71

9.2.3 Lining Material

Lining material	Main properties	Application scope
PFA	<ol style="list-style-type: none"> 1. Stable chemical properties, resistance to various acid, alkane, and salt solutions and various organic solvents. It is not tolerant to the corrosion of ClF₃, high-temperature OF₃ and high-speed liquid oxygen and ozone. 2. The anti-abrasion property is average. 	<ol style="list-style-type: none"> 1. -20~150°C 2. Strong corrosive medium such as concentrated acid and alkane.

9.2.4 Electrode Material

Electrode material	Anti-corrosion property
Stainless steel (316L)	It is applied in water, sewage and organic corrosive medium.

9.2.5 Housing Protection Rating(IP)

IP67

10. Appearance and Dimension

10.1 Tri-Clmp Type

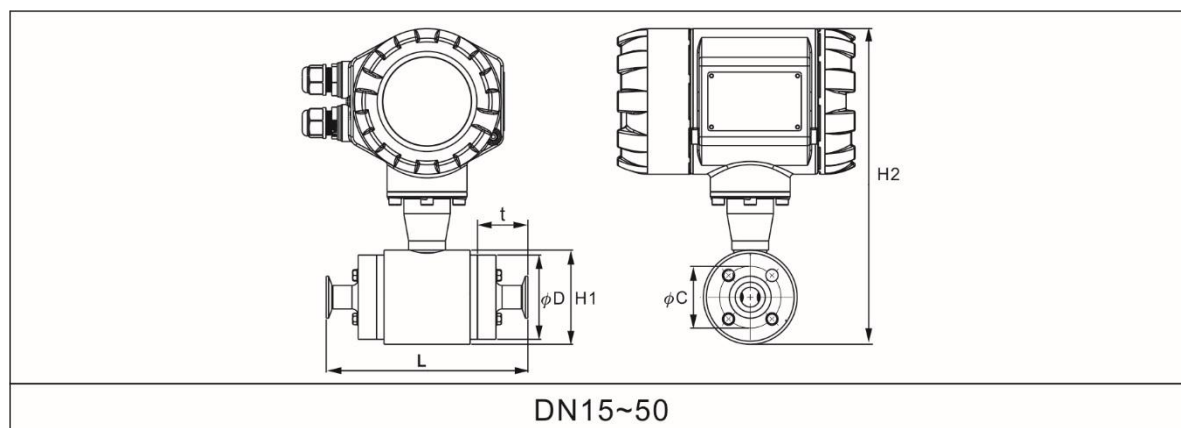

10.1.1 Tri-Clamp

Connection specification		Tri-Clamp			
Nominal diameter(mm)		15	25	40	50
Lining material		PFA			
Length	L	164	164	258.6	258.6
External diameter	ϕD	68.3	81.1	106.3	106.3
PCD	ϕC	50	60	83	83
Flange thickness	t	41	41	61.5	61.5
Quantity of screw holes	N	4	4	4	4
Height of sensor casing	H1	76.3	89.1	114.3	114.3
Total height	H2	256	270	294	294
Weight(kg)	--	4.9	5.7	8.6	9.1

Connection specification

Tri-Clamp	DN	di (mm)	G (mm)
	15	15.8	25
	25	22.1	50.5
	40	34.8	50.5
	50	47.5	64

11. Installation

The design, test and power supply for the flow meter are based on the related regulations. User must strictly follow the instructions to guarantee the safe operation and normal working of the flow meter.

11.1 Conditions required to guarantee the measurement accuracy of the electromagnetic flow meter:

- The test liquid is conducting.
- The measuring pipe must be filled with liquid.
- The test liquid must be uniform, so as to prevent the non-uniform conductivity (which will result in serious interference). If you need to add some chemicals dynamically, it should be added in the downstream of the flow meter.
- The electromagnetic flow meter must be well grounded. Especially in the plastic pipe, the grounding ring must be installed in order to perform solid grounding.
- The straight tube section is required to be at least 5D at the flow meter inlet (internal diameter of the measuring pipe), and at least 2D at the flow meter outlet.
- The flow meter should be kept away from strong EMI, and it should not be installed near the large motors or transformers.

11.2 Safety Measures

To guarantee human and device safety, the instructions below must be followed:

- Before selecting the location and installing the flow meter, the user should carefully read the related parts in this manual, and consider the safety requirements for the flow meter, related devices and machine body environment.
- The flow meter installation and repair must be performed by the personnel with some flow meter knowledge.
- The flow meter sensors and pipes must be correctly installed, and the sealing must be safe and reliable. The liquid pressure should not exceed the maximum working pressure described on the flow meter specification.
- Proper measures must be taken to prevent electrical shock accident.
- The handling equipment of the flow meter should meet the safety requirements.

11.3 Inspection before Installation

- Check whether the flange, lining, casing and outgoing line sleeve are damaged.
- Open the box cover to check whether the wiring printed circuit is loosened or damaged.
- Check whether the model number on the nameplate is consistent with the order information.

11.4 Handling

The flow meter must be handled with the correct handling method. The safety load and protection action of the handling equipment should meet the related regulations. The transmitter box (for integrated flow meter) or enclosure (for separated flow meter) must not be tied up to handle the flow meter.

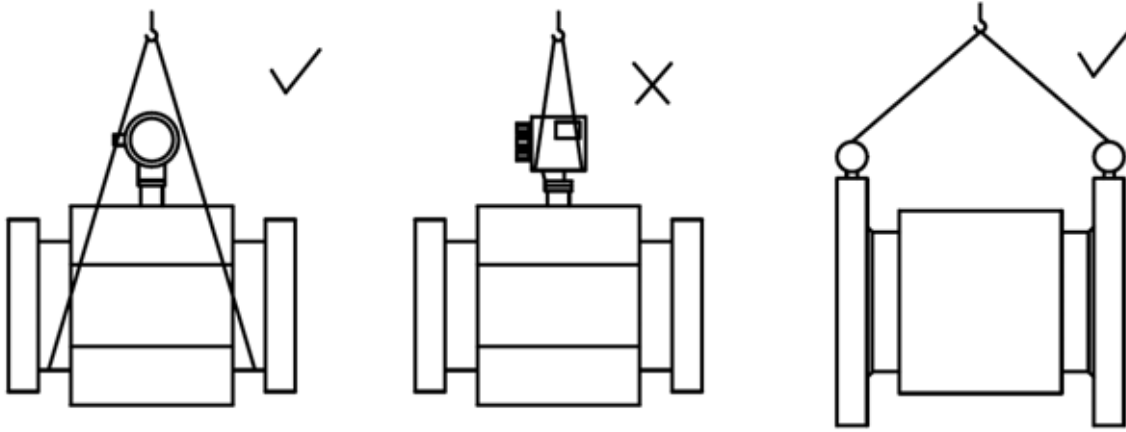

11.5 Correct Installation

It is very important to select the installation site and install the flow meter correctly. If any mistake is made during the installation, it will affect the measuring accuracy or the life span of the flow meter, or even cause damage. When selecting the installation site, please pay special attention to the following:

- a. The axis of the measuring electrode must be approximate to the horizontal direction (Generally, the angle from the level line is within 10° .)

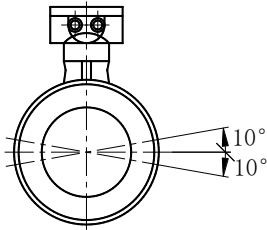

- b. The measuring pipe must be filled with liquid.
- c. The flow meter must be equipped with the straight tube section in the length of at least $5 \times D$ at the front side (D is the internal diameter of the flow meter), and the straight tube section in the length of at least $2 \times D$ at the rear side (D is the internal diameter of the flow meter).



- d. The flowing direction of the fluidic is the same as the arrow direction on the flow meter.

- e. Please prevent the vacuum in the pipe, which will damage the lining of the flow meter.
- f. The flow meter must be free from strong electromagnetic field. The magnetic intensity of the flow meter installation site must be smaller than 400A/m. (It should not be installed near large motors or transformers)
- g. There should be enough space left surrounding the flow meter for installation and repair.
- h. If the measuring pipe vibrates, a support frame should be set up on both sides of the flow meter.
- i. When measuring the mixture of different media, the distance between the mixing point and the flow meter must be $30 \times D$ at least (D is the internal diameter of the flow meter).
- j. For convenient cleaning and maintenance of the flow meter, a bypass pipe must be installed.

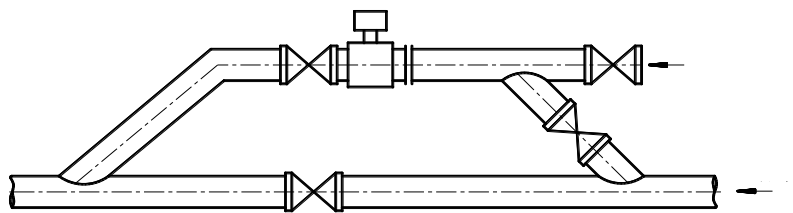

- k. When installing the flow meter of the PTFE lining, the bolt connecting two flanges should be fastened evenly. Otherwise, it will damage the PTFE lining. Please use the torque wrench as much as possible.
- l. The flow meter should be protected from strong vibration and great temperature change. In the meantime, damage of the corrosive liquid on the flow meter should be prevented.
- m. If the flow meter is installed at a position with direct sunlight, shielding facilities should be set up.
- n. When installing the sensor, the measuring pipe and the process pipe must be on the same axial line. For the sensor with the nominal diameter of DN50 or below, the axial line deviation should not exceed 2mm. For those of DN65~DN150, the axial line deviation should not exceed 3mm. For those of \geq DN200, the axial line deviation should not exceed 4mm.
- o. The shim installed between the flanges should have excellent anti-corrosion property. The shim should not intrude in the pipe, which will block the flowing fluidic
- p. Fasten the bolts and screws of the flow meter. The screw threads should be undamaged with good lubrication condition. The bolts with torque wrench must be fastened based on the flange size and torque.
- q. When welding or flame-cutting the pipes near the sensor, isolation measure must be conducted, so as to prevent the lining from heating. Moreover, the flow meter must be powered off, or it will damage the flow meter.

11.6 Notes for Installation on the Pipe

When installing the flow meter, one must follow the installation diagrams as shown below. This will ensure the flow meter can guarantee the pipe is always filled with the liquid: (The figures below are only typical cases, which don't include all feasible installation methods. The user may judge the installation position based on the actual condition.)

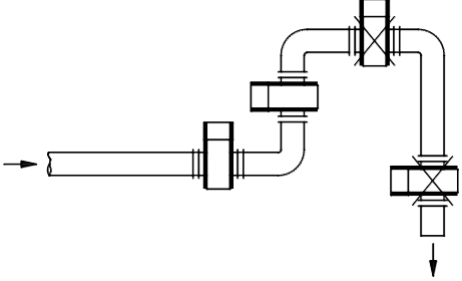
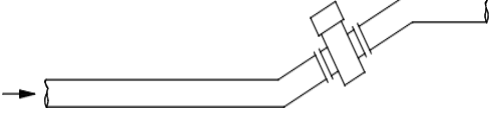
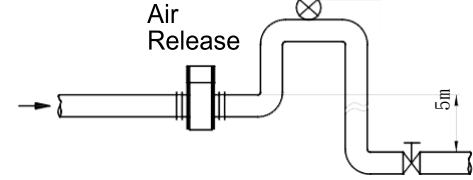
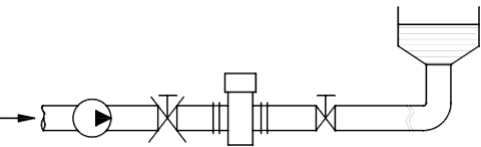
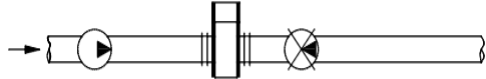
No.	Diagram	Description
1		<ul style="list-style-type: none"> ■ It should be installed at the lower point and the vertically upward point of the horizontal pipe. ■ Don't install it at the highest point and the vertically downward point of the pipe.
2		<ul style="list-style-type: none"> ■ It should be installed at the rising point of the pipe.
3		<ul style="list-style-type: none"> ■ If the pipe gap exceeds 5m, the air release valve should be installed at the downstream of the sensor. The downstream of the sensor should have some back pressure.
4		<ul style="list-style-type: none"> ■ The control valve and cut valve should be installed at the downstream of the sensor rather than the upstream.
5		<ul style="list-style-type: none"> ■ The sensor should be installed at the pump outlet rather than the inlet.

11.7 Grounding Requirements

The grounding of the electromagnetic flow meter is very important. If the grounding is poor, it won't work normally. The sensor and transmitter should be equipped with high-quality independent grounding wire (The section area of the copper core is 1.6mm²). The grounding resistance should be <10Ω.

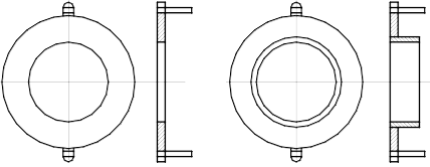
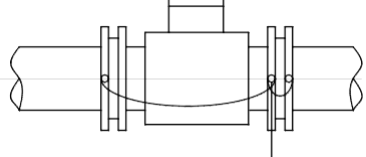
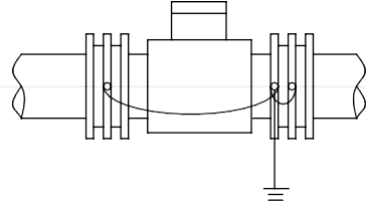
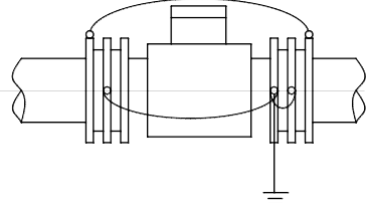
	Diagram	Description
Grounding Ring		<ul style="list-style-type: none"> ■ The grounding ring is needed if the pipe connecting with the sensor is insulating. ■ The same material as the electrode should be chosen, to prevent corrosion by the liquid. ■ If the test medium is abrasive, the neck grounding ring should be selected.
Grounding Method		<ul style="list-style-type: none"> ■ It is for installing the flow meter on the metal pipe not coated with insulating layer.
		<ul style="list-style-type: none"> ■ When installing the flow meter on the plastic pipe or the pipe with insulating coating material, paints or lining, grounding rings on both ends of the sensor should be installed.
		<ul style="list-style-type: none"> ■ When installing the flow meter on the protective pipe of cathode, the pipe with the protection of electrolytic corrosion generally has insulating walls and external sides. Thus, during installation, the grounding ring and the flanges on the pipe should be insulating.

11.8 Changing the Direction of the Transmitter Box

The transmitter box can change into four different directions as needed.

- a. Changing the direction of the transmitter box for the integrated flow meter.
 1. Remove 4 hex screws used to fasten the transmitter.
 2. Rotate the transmitter to the target direction, and pay attention to the internal connecting wire during rotation.
 3. Fasten the transmitter again.

12. Wiring and Using

12.1 Wiring

12.1.1 Notes for Wiring

- For the power line, the 2-core rubber insulated cable is recommended.
- For AC power supply, L1 should be “Live Wire”.
- The wiring of all terminal blocks should be clamped with slotted terminal and performed with insulation. The cable must be prevented from intruding into the terminal block directly.
- The total impedance of the outgoing cable on the current output terminal should not be larger than the value stated in the specification.
- The pulse or frequency output is NPN transistor output generally, which requires external power supply.

12.1.2 Open the external cover on the rear side, you will see the wiring terminal as shown below.

DC24V

Digital output 1		RS-485 communication		Digital input	
DO1-	DO1+	D-	D+	DI-	DI+
V+	V-	P-	P+	mA-	mA+
DC24V		Voltage pulse output		4-20mA output	

13. Inspection before Power-On

1. Check whether the flow meter is damaged during transportation and installation.
2. Check whether the voltage of the power supply is consistent with that specified on the nameplate.
3. Check whether the fuse used is of the correct current value.
4. Check whether the flow meter is grounded correctly.
5. Open the pipe valve to fill the pipeline system with liquid. One should pay attention to removing the leaked gas and residuals in the system.
6. Power on the flow meter to warm up for 10 minutes. Then it can work normally.

14. Parameter Functions

14.1 Procedure for Menu Setting

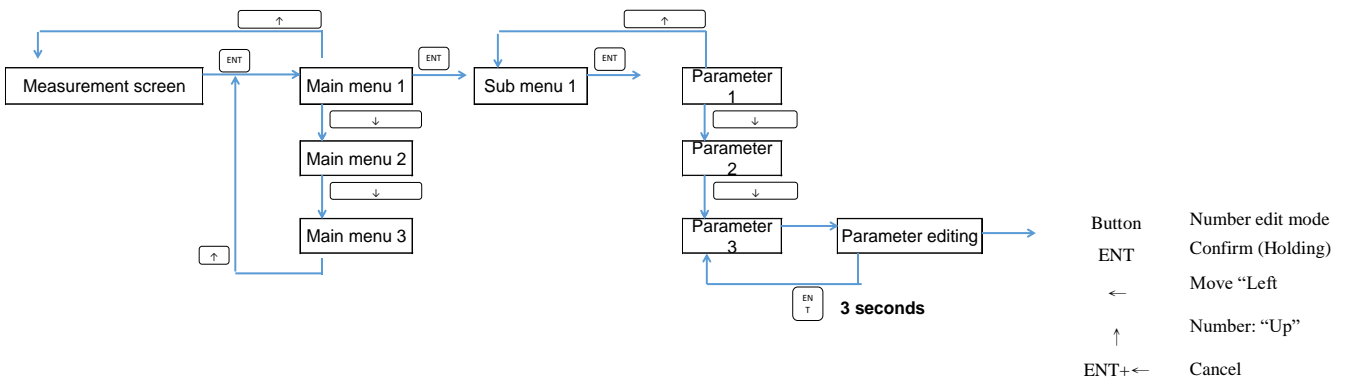

14.1.1 Functions of the Display Interface

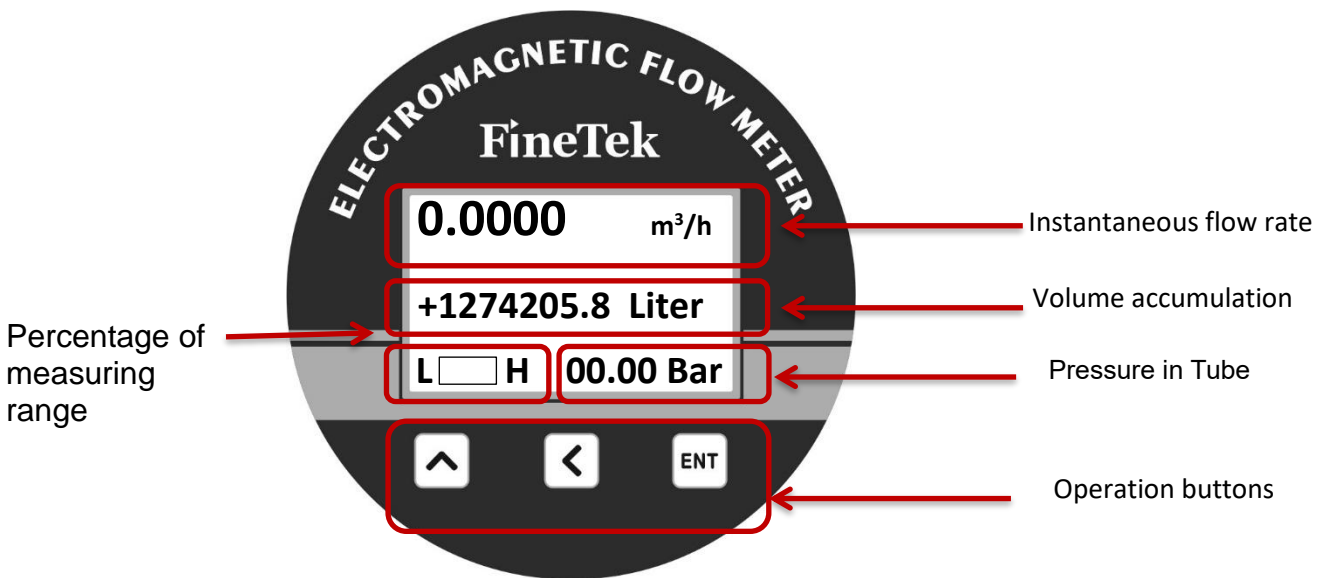

14.1.2 Button Functions in Parameter Setting Status:

Button	Main Measuring Page	Menu Mode	Parameter Setting Page		
			Read Only	Number Edit Mode	List Edit Mode
ENT	Enter menu	Enter sub menu		Confirm button (Keep pressing)	Confirm button (Keep pressing)
<		Return to the previous page	Return to the previous	"Left" button	Return to the previous page
^		Sub menu option 【Down】		Number: "Plus" button	Option: Next page
ENT+ <				Cancel	

14.2 Various Parameter Setting Ranges

Main Menu	Sub Menu	Unit	Default	Setting Range
Fast Set (0)	Device Tag Num (1.1)			
	Zero Adj.(2.1)			
	Flow Span (1.5)			
	Flow Unit (1.4)			
	Low cutoff (2.4)			
	Damping Time (3.1)			
	Pulse Out Unit (3.3)			
Total Reset (1.9)				

Main Menu	Sub Menu	Unit	Default	Setting Range
Basic Set (1)	Device Tag Num (1.1)	none	00001	00001~65535
	Measure Type (1.2)	-	Water	Water
	Tube Size (1.3)	mm	actual	10,15,25,32,40,50,65,80,100
				125,150,200,250,300,350,400,450,500
	Flow Unit (1.4)	-	m ³ /h	L/(s,min,h), m ³ /(s,min,h), gal/(s,min,h),kg(s,min,h), Ton(s,min,h) (Flow rate* Liquid density = weight) "L/s","L/m","L/h","m ³ /s","m ³ /m","m ³ /h","gal/s","gal/m","gal/h","kg/s","kg/m","kg/h","Ton/s","Ton/m","Ton/h","m ³ /d"
	Flow Span (1.5)	=Flow Rate Unit	(5m/s) x (Diameter/2) ² x pi x Unit of Flow	(0.1 ~ 10.0m/s) x (Diameter/2) ² x pi x Unit of Flow (000.00)
	Direction (1.6)	dir	Forward	Forward,Reverse
	Total Unit (1.7)	-	m ³	Liter,gal, m ³ ,kg,Ton
	Total Mode (1.8)	none	Forward	Forward,Reverse,Bi-direction
Total Reset (1.9)	none	Cancel	Cancel,Accept	

Main Menu	Sub Menu	Unit	Default	Setting Range
Advanced Set (2)	Zero Adj. (2.1)	m/s	actual	-0.5000~+0.5000
	K-Factor (2.2)	none	1.000	0.000~3.000
	Density (2.3)	g/cm ³	1.0000	0.0001~9.9999
	Low cutoff (2.4)	%	0.5	0.00~100.00
	Fwd. Init. (2.5)	=Total Unit	0	0~9999999999
	Rev. Init. (2.6)	=Total Unit	0	0~9999999999

Main Menu	Sub Menu	Unit	Default	Setting Range
I/O Signal Set (3)	Damping Time (3.1)	second	3	0~100
	Pulse Out Mode (3.2)	none	Pulse NO	Pulse NO, Pulse NC, Frequency
	Pulse Out Unit (3.3)	Unit/pulse	0.1 L	0.001~100(L,gal, m ³ ,g,kg,Ton) L/pulse,gal/pulse, m ³ /pulse,g/pulse, kg/pulse,Ton/pulse
	Max. Freq. (3.4)	kHz	2K	0.001~8K (00.000)
	Curr. Mode (3.5)	none	4-20	4-20,0-20
	4mA Fine-Tune (3.6)	count	0	-5000~5000
	20mA Fine-Tune (3.7)	count	0	-5000~5000
	Input1 Func. (3.8)	N/A	None	None, Total Reset
	Input1 Type (3.9)	N/A	NO	NO,NC
	Filter Variation(3.10)	m/s	1	00.000~10.000
	Filter Weight(3.11)	%	10	0~100
	Median Filter(3.12)	%	Enable	Disable,Enable

Main Menu	Sub Menu	Unit	Default	Setting Range
Alarm Set (4)	Max. Flow (4.1)	Flow Rate Unit	Max.	Max. Flow Rate
	Min. Flow (4.2)	Flow Rate Unit	min.	Min. Flow Rate
	Empty Tube Set (4.3)	N/A	Enable	Enable, Disable
	Output 1 Func. (4.4)	N/A	Max. Flow Rate	Max. Flow Rate, Min. Flow Rate, Empty Tube, System Alarm
	Output 1 Type (4.5)	N/A	NO	NO,NC
	Output 2 Func. (4.6)	N/A	Min. Flow Rate	Max. Flow Rate, Min. Flow Rate, Empty Tube, System Alarm
	Output 2 Type (4.7)	N/A	NO	NO,NC
	Curr. Func. (4.8)	N/A	None	Empty Tube, System Alarm
	Alarm Curr. (4.9)	mA	3.6	3.6,3.8,20.5,22
	Temp. Alarm.(4.10)	N/A	1	0: OFF, 1: ON

Main Menu	Sub Menu	Unit	Default	Setting Range	
	System Info.(5.2)	Tube Status	N/A	Actual	Normal, Empty
		Resistance	m/s	Actual	N/A
		Status Code	kΩ	Actual	N/A
		Act. Flow Speed	N/A	Actual	0000 0000 ~ FFFF FFFF
	Self-Test(5.3)	N/A	N/A	Cancel	Normal, Circuit Fail ,Excitation Fail, Amb. Temp, Electrode Coating
	Analogy Input(5.4)	4mA Display	N/A	0000	0~9999
		20mA Display.	N/A	1000	0~9999
		4-20mA Unit	N/A	Kpa	None, Kpa, Mpa, Psi, Bar, °C, °F
		Dot	N/A	1	0~3
	ModBus Comm.(5.5)	BaudRate(2.13.2)	N/A	1	1~255
		Modbus ID(2.13.1)	BPS	9600	1200,2400,4800,9600, 19200,38400,57600
		Stop bit(2.13.5)	N/A	8	8,9
		Data bit(2.13.3)	N/A	none	none,odd,even
		Parity(2.13.4)	N/A	1	1,2
	Recovery Default(5.6)	N/A	N/A	Cancel	Cancel, Accept
	Mains Frequency(5.7)	N/A	Hz	50	50, 60
	LCM Contrast Brightness(5.8)	N/A	N/A	32	15~40
	Manu Password (5.9)	User Password(5.9.1)	N/A	00000	0~99999
		Admin Password(5.9.2)			

Main Menu	Sub Menu	Unit	Default	Setting Range
Simulation(6)	Flow Speed(6.1)	m/s	0	-10 ~ 10
	Flow Rate(6.2)	unit of flow	0	0~Max.
	Output Curr.(6.3)	mA	4mA	3.6~22
	Output Freq.(6.4)	Hz(pulse/sec)	2	2~8000
	Output1 Status(6.5)	N/A	OFF	ON/OFF
	Output2 Status(6.6)	N/A	OFF	ON/OFF
	Input1 Status(6.7)	N/A	Actual	ON/OFF
	Input Curr.(6.8)	N/A	Actual	0~24mA

Main Menu	Sub Menu	Unit	Default	Setting Range
System Log (7)	Date Set (7.1)	Actual	Actual	year : 17~99, month : 01~12, day : 01~31
	Time Set (7.2)	Actual		hour : 00~23, minute : 00~59, sec : 00~59
	Log data clear (7.3)	N/A	Cancel	Cancel, Accept
	System Log Info (7.4)	N/A	Actual	N/A

Main Menu	Sub Menu	Unit	Default	Setting Range
Information(8)	F.W. Version(8.1)		Actual	

※Sub menu 1.3、1.9、2.2、2.5、2.6、5.6、5.9、7.3, only the admin can change.

14.3 System record illustration

Display image illustration

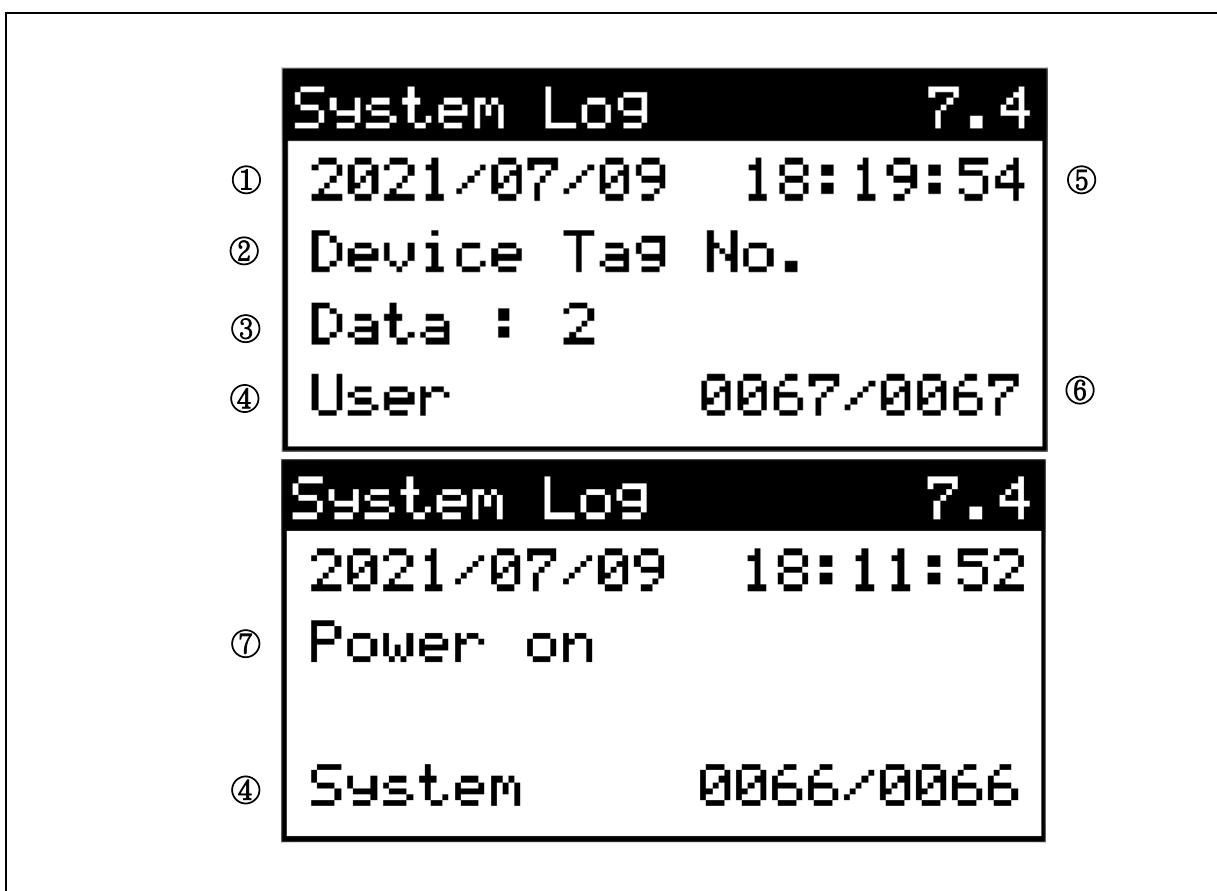

Item	Description
1	Date of event occurred
2	Name of modified parameter, modifier is "User", "Admin"
3	The contents of modified parameter
4	Operator for modifying parameters, divided into "User", "Admin", and "System"
5	Time of event occurred
6	Current total number of records
7	Names of system events, the modification is by "System", see the table below for details

Classification	Message	Description
Hardware status"	Power on	Record the current time when the system is booted"
	Power off	Record the current time when the system is shut down"
User setting"	Total reset	Only permitted when user is "Admin"
	K-Factor	Only permitted when user is "Admin"
	Tube size	Only permitted when user is "Admin"
	Admin password	Only permitted when user is "Admin"
	User password	Permitted for both ""User"" or "Admin"
	Set default	Only permitted when user is "Admin"
	Others	Refer to the parameter setting function description 14.2 for the authority classification."

15. Ordering Information

Model Number	Order Code
EPD36	EPD10300-A

EPD1 0 3 0 0 -A ^⑩ ^⑪ ^⑫ I 0 0 MC 1 4 MC A D F 0 0 0 0

⑩⑪⑫ Pipe diameter

- 015: 15mm
- 025: 25mm
- 040: 40mm
- 050: 50mm

⑬⑭⑮ Connection specification

- I 00: Tri-clamp

⑯⑰ Connection material

- MC: SUS316L

⑱⑲ Lining material

- 14: PFA

⑳㉑ Electrode material

- MC: SUS316L

㉓ Power supply

- A: 100~240Vac, 50/60Hz
- D: 24Vdc
- N: 100~240Vac,50/60Hz with date logger
- R: 24Vdc with date logger

㉔ Accuracy

- F: 0.5%

16. Transportation and Storage

To prevent the flow meter from damage during the transportation, please keep the packaging condition as how it was when it was shipped from the factory before arriving at the installation site. The storage conditions should meet the following:

- Appropriate rainproof and damp-proof treatment must be conducted .
- Vibration must be reduced and collision with other objects must be prevented during its transportation.
- The storage temperature must be in the range of $-20\sim 70^{\circ}\text{C}$
- The humidity should be lower than 80%
- To store the used sensors, clean the tested medium attached on the lining and the electrode, and avoid oxidation by not exposing it to too much air for a long time.
- Outdoor storage may degrade the performance of the flow meter.

17. Fault Inspection and Repair

When fault occurs to the flow meter or it fails to meet the accuracy requirements, please try to fix it by referring to the table below.

Fault	Inspection	Solution
Inaccuracy	<ul style="list-style-type: none"> ■ Is the flowmeter's zero point shifting? 	<ul style="list-style-type: none"> ■ Perform zero-point calibration. Refer to the menu. Ensure the pipe is fully filled with liquid and there is no liquid flo
	<ul style="list-style-type: none"> ■ Is the pipe fully filled with liquid? 	<ul style="list-style-type: none"> ■ Adjust the installation position to ensure the pipe is
	<ul style="list-style-type: none"> ■ Is the flowmeter operating near its upper or lower flow range 	<ul style="list-style-type: none"> ■ Adjust the flow rate to be between 1 m/s and 10 m/s.
	<ul style="list-style-type: none"> ■ Is the range setting correct? 	<ul style="list-style-type: none"> ■ Ensure the flowmeter's range matches the range set in the.
	<ul style="list-style-type: none"> ■ Are the output connections of the flowmeter correct? 	<ul style="list-style-type: none"> ■ Reconnect and ensure the wiring is smooth.receiving
	<ul style="list-style-type: none"> ■ Is the grounding between the flowmeter and the pipeline proper? 	<ul style="list-style-type: none"> ■ Correctly ground the flowmeter, ensuring the resistance does not exceed 10Ω.
<ul style="list-style-type: none"> ■ Is the sensor K-coefficient value consistent with the sensor label? nameplate. 	<ul style="list-style-type: none"> ■ If the K-coefficient has been altered, restore it to the original value. 	
No Display on Startup	<ul style="list-style-type: none"> ■ Are the power supply, switch, and fuse functioning properly? 	<ul style="list-style-type: none"> ■ Resolve power supply issues so the flowmeter can obtain power correctly. ■ The flowmeter might be damaged. Contact the original manufacturer or reseller.
Communication Failure	<ul style="list-style-type: none"> ■ Is the RS-485 communication functioning? 	<ul style="list-style-type: none"> ■ Confirm that the RS-485 converter is working correctly. ■ Are the RS-485 bit format/ID/ baud rate parameters correct?

No Pulse Output	<ul style="list-style-type: none"> ■ Is there an external 12VDC power supply to the output terminal? 	<ul style="list-style-type: none"> ■ Factory default is NO power supply passive NPN output; external power is required.
Unstable Display Values	<ul style="list-style-type: none"> ■ Is the liquid in the pipeline of low conductivity? 	<ul style="list-style-type: none"> ■ Compare with the pipeline material characteristics.
	<ul style="list-style-type: none"> ■ Is the grounding ring missing or poorly connected? 	<ul style="list-style-type: none"> ■ Check the order details. Regardless of the pipe material, there must be a grounding ring. Please read the operation manual on how to use it.
	<ul style="list-style-type: none"> ■ Is the flowmeter installed near a high-voltage interference zone? 	<ul style="list-style-type: none"> ■ Reroute the signal or power lines away from the
	<ul style="list-style-type: none"> ■ Is moisture or condensation causing interference in an empty pipe? 	<ul style="list-style-type: none"> ■ Enable empty pipe alarms.
	<ul style="list-style-type: none"> ■ Is there leakage voltage in the flowmeter power live wire? 	<ul style="list-style-type: none"> ■ Reroute the power supply line and reset the flowmeter to factory settings. Reconfigure parameters such as pipe size and K-factor.
	<ul style="list-style-type: none"> ■ The transmitter or main circuit board might be damaged. 	<ul style="list-style-type: none"> ■ Replace with the spare circuit board or contact the manufacturer.
Flow is Present but No Flow Value Displayed	<ul style="list-style-type: none"> ■ Is the low flow cut-off value (shield value) higher than the current flow? 	<ul style="list-style-type: none"> ■ Adjust and lower the cut-off value (refer to factory settings).
	<ul style="list-style-type: none"> ■ Are the signal and excitation wires in the separated flowmeter functioning properly? 	<ul style="list-style-type: none"> ■ Verify correct wiring and tighten the terminal blocks at both ends.
	<ul style="list-style-type: none"> ■ Is the sensor arrow aligned with the pipeline flow direction? 	<ul style="list-style-type: none"> ■ Confirm the sensor orientation and set the fluid flow direction correctly.
	<ul style="list-style-type: none"> ■ Is the pipeline filled with liquid? 	<ul style="list-style-type: none"> ■ Ensure that the sensor is installed at the concave part of the horizontal pipeline or at a raised section behind the pipeline. Ensure that the pipe is full.

Abnormal Messages on Display	<ul style="list-style-type: none"> Refer to the manual for abnormal message descriptions. 	<ul style="list-style-type: none"> Follow the manual's troubleshooting instructions.
Flowmeter Inner Lining Raised Up	<ul style="list-style-type: none"> Is negative pressure causing the issue? 	<ul style="list-style-type: none"> Remove the negative pressure or consider switching to another product.
Abnormal 4-20mA Output	<ul style="list-style-type: none"> Is there no current output? 	<ul style="list-style-type: none"> Remove the existing wiring and test with a handheld multimeter. Confirm the product functionality. Restore factory settings and retest. Contact local technical personnel if the issue
Large Measurement Error	<ul style="list-style-type: none"> Are the filter settings incorrect? 	<ul style="list-style-type: none"> Reduce the signal averaging time and disable the median filter function.
	<ul style="list-style-type: none"> Are there deposits on the lining or electrodes? 	<ul style="list-style-type: none"> Inspect and clean any deposits on the electrodes.
	<ul style="list-style-type: none"> If the above-mentioned checkings are not found; 	<ul style="list-style-type: none"> Contact local technical personnel for further assistance.

Error code description

Warning status	Directions
Empty Tube	When measuring, there is no liquid in the pipe, or the liquid conductivity is below 5 μ s/cm
Sensor Discon.	The sensor is not properly connected, or the excitation current is abnormal, making it unable to detect the flow correctly.
Electrode Coating	The electrodes are severely covered with non-conductive substances.
Init. Comm. Err.	Internal malfunction. (Please try restarting.)

18. MODBUS Communication Protocol

Address(Hex)	Address(Dec)	Variable Name	Data Type	Unit	Range	Definition	Authority
0x1000	4096	gt_modbus_slave_fine_tek_id[0]	UINT8	N/A		"FI"	Read only(Header)
0x1001	4097	gt_modbus_slave_fine_tek_id[2]	UINT8	N/A		"NE"	Read only(Header)
0x1002	4098	gt_modbus_slave_fine_tek_id[4]	UINT8	N/A		"-T"	Read only(Header)
0x1003	4099	gt_modbus_slave_fine_tek_id[6]	UINT8	N/A		"EK"	Read only(Header)
0x1004	4100	PFC_PRODUCT_TYPE	UINT16	N/A		"FM"	Read only(Header)
0x1005	4101	PFC_PRODUCT_NUMBER	UINT16	N/A		0x0001	Read only(Header)
0x1006	4102	PFC_PRODUCT_VERSION	UINT16	N/A		0x0001	Read only(Header)

0x1010	Measuring Status		Data Type	Unit	Range	Definition	Authority
0x1010	4112	PFC_FlowTotal_FRAM_FWD_VAL-High	FLOAT64	m ³		Forward accumulated flow capacity	Read only
0x1011	4113	PFC_FlowTotal_FRAM_FWD_VAL+1					Read only
0x1012	4114	PFC_FlowTotal_FRAM_FWD_VAL+2					Read only
0x1013	4115	PFC_FlowTotal_FRAM_FWD_VAL-Low					Read only
0x1014	4116	PFC_FlowTotal_FRAM_REV_VAL-High	FLOAT64	m ³	Backward accumulated flow capacity	Read only	
0x1015	4117	PFC_FlowTotal_FRAM_REV_VAL+1				Read only	
0x1016	4118	PFC_FlowTotal_FRAM_REV_VAL+2				Read only	
0x1017	4119	PFC_FlowTotal_FRAM_REV_VAL-Low				Read only	
0x1018	4120	PFC_FlowTotal_FRAM_BI_DIR_VAL-High	FLOAT64	m ³	Two-way accumulated flow capacity	Read only	
0x1019	4121	PFC_FlowTotal_FRAM_BI_DIR_VAL+1				Read only	
0x101A	4122	PFC_FlowTotal_FRAM_BI_DIR_VAL+2				Read only	
0x101B	4123	PFC_FlowTotal_FRAM_BI_DIR_VAL-Low				Read only	
0x101C	4124	PFC_FlowRate_Main_Val-High	FLOAT64	Rate Unit	Instant flow rate value	Read only	
0x101D	4125	PFC_FlowRate_Main_Val+1				Read only	
0x101E	4126	PFC_FlowRate_Main_Val+2				Read only	
0x101F	4127	PFC_FlowRate_Main_Val-Low				Read only	
0x1020	4128	gb_pfc_flowrate_rawdata_m_s-High	FLOAT64	m/s	\Setting\ Information\ Actual flow rate	Read only	
0x1021	4129	gb_pfc_flowrate_rawdata_m_s+1				Read only	
0x1022	4130	gb_pfc_flowrate_rawdata_m_s+2				Read only	
0x1023	4131	gb_pfc_flowrate_rawdata_m_s-Low				Read only	
0x1024	4132	gf_pfc_current_out_value-High	FLOAT32	mA	Output current value	Read only	
0x1025	4133	gf_pfc_current_out_value-Low				Read only	
0x1026	4134	PFC_SIMULATION_INPUT_CURR-High	FLOAT32	mA	lutput current value	Read only	
0x1027	4135	PFC_SIMULATION_INPUT_CURR-Low				Read only	
0x1028	4136	gb_pfc_liquid_resistance-High	FLOAT32	KΩ	\Setting\ Information\ Liquid resistance value	Read only	
0x1029	4137	gb_pfc_liquid_resistance-Low				Read only	
0x102A	4138	PFC_FlowTotal_FWD_VAL-Low	UINT32	Liter	Forward accumulated flow capacity	Read only	
0x102B	4139	PFC_FlowTotal_FWD_VAL-High				Read only	
0x102C	4140	PFC_FlowTotal_REV_VAL-Low	UINT32	Liter	Backward accumulated flow capacity	Read only	
0x102D	4141	PFC_FlowTotal_REV_VAL-High				Read only	
0x102E	4142	PFC_FlowTotal_BI_VAL-Low	UINT32	Liter	Two-way accumulated flow capacity	Read only	
0x102F	4143	PFC_FlowTotal_BI_VAL-High				Read only	
0x1030	4144	PFC_Flowrate_Main_Vluæ-Low	FLOAT32	Rate Unit	Instant flow rate value	Read only	
0x1031	4145	PFC_Flowrate_Main_Vluæ-High				Read only	
0x1032	4146	PFC_Flowrate_rawdata_vluæ-Low	FLOAT32	m/s	\Setting\ Information\ Actual flow rate	Read only	
0x1033	4147	PFC_Flowrate_rawdata_vluæ-High				Read only	

0x1040 System status			Data Type	Unit	Range	Definition	Authority
0x1040	4160	PFC_TEMPERATURE_BOARD_NOW-High	FLOAT32	°C		PCB temp.	Read only
0x1041	4161	PFC_TEMPERATURE_BOARD_NOW-Low					Read only
0x1042	4162	PFC_SELF_TEST_TUBE_STATUS	UINT16	N/A	0: Normal 1: Empty	\Setting\ Information\ Status of pipe	Read only
0x1043	4163	pfc_system_status_code_value-High	UINT32	N/A		\Setting\ Information\ system status code	Read only
0x1044	4164	pfc_system_status_code_value-Low					Read only

0x1050 Paramter setting- System information			Data Type	Unit	Range	Definition	Authority
0x1050	4176	PFC_PRODUCT_VERSION	UINT16	N/A		Version of firmware (Master)	Read only

0x1055 Parameter setting- Basic setting			Data Type	Unit	Range	Definition	Authority
0x1055	4181	PFC_BASIC_SET_DEVICE_TAG_NUM	UINT16	N/A	00001~65535(Default:1)	Basic setting/ ID number	Read /Write
0x1056	4182	PFC_BASIC_SET_MEASURE_TYPE		N/A	0:Water 1:none	Measured object	Read /Write
0x1057	4183	PFC_BASIC_SET_TUBE_SIZE-High	FLOAT32	10~100mm	Line size divided by 1000	Basic setting/ Connection size	Read /Write
0x1058	4184	PFC_BASIC_SET_TUBE_SIZE-Low		125~500mm	e.g.: DN80= 80/1000=0.08		
0x1059	4185	PFC_BASIC_SET_FLOW_RATE_UNIT	UINT16	N/A	0:L/m 1:L/h 2:m3/m 3:m3/h 4:gal/m 5:gal/h 6:kg/m 7:kg/h 8:T/m 9:T/h 10:m3/d	Basic setting/Instant flow rate unit	Read /Write
0x105A	4186	PFC_BASIC_SET_FLOW_SPAN-High	FLOAT64	m³/s	+Line size(m)^2 *0.0785 ~ Line size(m)^2 *7.85	Basic setting/Measuring range of full pipe	Read /Write
0x105B	4187	PFC_BASIC_SET_FLOW_SPAN+1					Read /Write
0x105C	4188	PFC_BASIC_SET_FLOW_SPAN+2					Read /Write
0x105D	4189	PFC_BASIC_SET_FLOW_SPAN-Low					Read /Write
0x105E	4190	PFC_BASIC_SET_FLOW_DIR	UINT16	N/A	0: Forward 1: Backward	Basic setting/Flow direction	Read /Write
0x105F	4191	PFC_BASIC_SET_FLOW_TOTAL_UNIT	UINT16	N/A	0:Liter1:gal2:m33:kg4:Ton	Basic setting/ Accumulated flow capacity unit	Read /Write
0x1060	4192	PFC_BASIC_SET_TOTAL_MODE	UINT16	N/A	0: Forward 1: Backward 2: Two-way	Basic setting/ Accumulated flow capacity mode	Read /Write
0x1061	4193	PFC_BASIC_SET_TOTAL_RESET	UINT16	N/A	0: Cancel 1: Confirm	Basic setting/ Reset accumulated flow capacity	Read /Write

0x1070	Parameter setting- Advanced setting		Data Type	Unit	Range	Definition	Authority
0x1070	4208	PFC_BASIC_SET_ZERO_ADJ-High	FLOAT64	m/s	-0.5000~+0.5000	Basic setting/ Zero point setting	Read /Write
0x1071	4209	PFC_BASIC_SET_ZERO_ADJ+1					Read /Write
0x1072	4210	PFC_BASIC_SET_ZERO_ADJ+2					Read /Write
0x1073	4211	PFC_BASIC_SET_ZERO_ADJ-Low					Read /Write
0x1074	4212	PFC_BASIC_SET_K_FACTOR-High	FLOAT64	N/A	+0.0000~+3.0000 (Default:1.0)	Basic setting/ K Factor setting	Read /Write
0x1075	4213	PFC_BASIC_SET_K_FACTOR+1					Read /Write
0x1076	4214	PFC_BASIC_SET_K_FACTOR+2					Read /Write
0x1077	4215	PFC_BASIC_SET_K_FACTOR-Low					Read /Write
0x1078	4216	PFC_ADVANCED_SET_DENSITY-High	FLOAT64	g/cm ³	+0.0001~+9.9999 (Default:1.0)	Basic setting/ Density	Read /Write
0x1079	4217	PFC_ADVANCED_SET_DENSITY+1					Read /Write
0x107A	4218	PFC_ADVANCED_SET_DENSITY+2					Read /Write
0x107B	4219	PFC_ADVANCED_SET_DENSITY-Low					Read /Write
0x107C	4220	PFC_BASIC_SET_LOW_FLOW_CUTOFF-High	FLOAT64	%	+0.0000~+100.00 (Default:0.5)	Basic setting/ Low rate shield	Read /Write
0x107D	4221	PFC_BASIC_SET_LOW_FLOW_CUTOFF+1					Read /Write
0x107E	4222	PFC_BASIC_SET_LOW_FLOW_CUTOFF+2					Read /Write
0x107F	4223	PFC_BASIC_SET_LOW_FLOW_CUTOFF-Low					Read /Write
0x1080	4224	PFC_ADVANCED_SET_FWD_TOTAL_INIT-High	FLOAT64	m3	0~99999	Advanced setting/ Forward accumulated flow ratestart value	Read /Write
0x1081	4225	PFC_ADVANCED_SET_FWD_TOTAL_INIT+1					Read /Write
0x1082	4226	PFC_ADVANCED_SET_FWD_TOTAL_INIT+2					Read /Write
0x1083	4227	PFC_ADVANCED_SET_FWD_TOTAL_INIT-Low					Read /Write
0x1084	4228	PFC_ADVANCED_SET_REV_TOTAL_INIT-High	FLOAT64	m3	0~99999	Advanced setting/ Backward accumulated flow ratestart value	Read /Write
0x1085	4229	PFC_ADVANCED_SET_REV_TOTAL_INIT+1					Read /Write
0x1086	4230	PFC_ADVANCED_SET_REV_TOTAL_INIT+2					Read /Write
0x1087	4231	PFC_ADVANCED_SET_REV_TOTAL_INIT-Low					Read /Write
0x1088	4232		UINT16	N/A	0~1	Zero point auto calibration ON/OFF	Read /Write

0x1090 Parameter setting- Output/Input signal setting			Data Type	Unit	Range	Definition	Authority
0x1090	4240	PFC_IO_SIGNAL_SET_DAMPING_TIME	UINT16	Second	000~+100(Default:3)	Output/Input signal setting/ Input signal average time	Read /Write
0x1091	4241	PFC_IO_SIGNAL_SET_PULSE_OUTPUT_MODE	UINT16	N/A	0:NO 1:NC 2: Frequency output	Pluse output mode	Read /Write
0x1092	4242	PFC_IO_SIGNAL_SET_PULSE_OUTPUT_UNIT-High	FLOAT64	Liter	+0.0010~+99.999 (Default:0.01)	Pluse unit setting	Read /Write
0x1093	4243	PFC_IO_SIGNAL_SET_PULSE_OUTPUT_UNIT+1					Read /Write
0x1094	4244	PFC_IO_SIGNAL_SET_PULSE_OUTPUT_UNIT+2					Read /Write
0x1095	4245	PFC_IO_SIGNAL_SET_PULSE_OUTPUT_UNIT-Low					Read /Write
0x1096	4246	PFC_IO_SIGNAL_SET_MAX_FREQ-High	FLOAT64	Hz	+0.0010~8.000 (Default:2.0)	Frequency setting	Read /Write
0x1097	4247	PFC_IO_SIGNAL_SET_MAX_FREQ+1					Read /Write
0x1098	4248	PFC_IO_SIGNAL_SET_MAX_FREQ+2					Read /Write
0x1099	4249	PFC_IO_SIGNAL_SET_MAX_FREQ-Low					Read /Write
0x109A	4250	PFC_IO_SIGNAL_SET_OUTPUT_CURR_MODE	UINT16	mA	0: 4-20mA 1: 0-20mA	Current output mode	Read /Write
0x109B	4251	PFC_IO_SIGNAL_SET_4MA_FINE_TUNE	INT16	Count	-5000.0~+5000.0 (Default:0)	4mA output adjustment	Read /Write
0x109C	4252	PFC_IO_SIGNAL_SET_20MA_FINE_TUNE	INT16	Count	-5000.0~+5000.0 (Default:0)	20mA output adjustment	Read /Write
0x109D	4253	PFC_IO_SIGNAL_SET_DIGITAL_1_IN_FUNC	UINT16	N/A	0: none 1: Reset	Input1 contact function	Read /Write
0x109E	4254	PFC_IO_SIGNAL_SET_DIGITAL_1_IN_TYPE	UINT16	N/A	0:NO 1:NC	Input1 contact form	Read /Write

0x10A5 Parameter setting- Alarm setting			Data Type	Unit	Range	Definition	Authority
---	--	--	-----------	------	-------	------------	-----------

0x10A5	4261	PFC_ALARM_SET_MAX_FLOW_RATE-High	FLOAT64	m ³ /s	+0.0000 ~ Line size(m) ² *7.85	Max. flow rate	Read /Write
0x10A6	4262	PFC_ALARM_SET_MAX_FLOW_RATE+1					Read /Write
0x10A7	4263	PFC_ALARM_SET_MAX_FLOW_RATE+2					Read /Write
0x10A8	4264	PFC_ALARM_SET_MAX_FLOW_RATE-Low					Read /Write
0x10A9	4265	PFC_ALARM_SET_MIN_FLOW_RATE-High	FLOAT64	m ³ /s	+0.0000 ~ Line size(m) ² *7.85	Min. flow rate	Read /Write
0x10AA	4266	PFC_ALARM_SET_MIN_FLOW_RATE+1					Read /Write
0x10AB	4267	PFC_ALARM_SET_MIN_FLOW_RATE+2					Read /Write
0x10AC	4268	PFC_ALARM_SET_MIN_FLOW_RATE-Low					Read /Write
0x10AD	4269	PFC_ALARM_SET_EMPTY_TUBE_DETECT	UINT16	N/A	0: Off 1: On	Empty pipe detection	Read /Write
0x10AE	4270	PFC_ALARM_SET_ALARM_1_FUNC	UINT16	N/A	0: None 1: Max. flow rate 2: Min. flow rate 3: Empty alarm 4: System error	Output 1 contact function	Read /Write
0x10AF	4271	PFC_ALARM_SET_ALARM_1_TYPE	UINT16	N/A	0:NO 1:NC	Output1 contact form	Read /Write
0x10B0	4272	PFC_ALARM_SET_ALARM_2_FUNC	UINT16	N/A	0: None 1: Max. flow rate 2: Min. flow rate 3: Empty alarm 4: System error	Output 2 contact function	Read /Write
0x10B1	4273	PFC_ALARM_SET_ALARM_2_TYPE	UINT16	N/A	0:NO 1:NC	Output2 contact form	Read /Write
0x10B2	4274	PFC_ALARM_SET_CURR_FUNC	UINT16	N/A	0: none 1: Empty alarm 2: System error	Alarm current function	Read /Write
0x10B3	4275	PFC_ALARM_SET_ALARM_CURR_VAL	UINT16	mA	0:3.6 1:3.8 2:20.5 3:22	Alarm current setting	Read /Write

0x10B9	4281	PFC_SYSTEM_SET_LANGUAGE	UINT16	N/A	0: English 1: Chinese (Traditional) 2: Chinese (Simple)	Language	Read /Write
0x10BA	4282	PFC_SYSTEM_SET_ANALOGY_INPUT_4MA INFO-High	FLOAT32	N/A	0~9999	Analog setting/ 4 mA Value	Read /Write
0x10BB	4283	PFC_SYSTEM_SET_ANALOGY_INPUT_4MA INFO-Low					
0x10BC	4284	PFC_SYSTEM_SET_ANALOGY_INPUT_20M A_INFO-High	FLOAT32	N/A	0~9999	Analog setting/ 20 mA Value	Read /Write
0x10BD	4285	PFC_SYSTEM_SET_ANALOGY_INPUT_20M A_INFO-Low					
0x10BE	4286	PFC_SYSTEM_SET_ANALOGY_INPUT_4_2 OMA_UNIT	UINT16	N/A	0:None 1:Kpa 2:Mpa 3:Psi 4:Bar 5:°C 6:°F	4~20 mA input unit	Read /Write
0x10BF	4287	PFC_SYSTEM_SET_ANALOGY_INPUT_DOT	UINT16	N/A	0~3	Decimal digits	Read /Write
0x10C0	4288	PFC_IO_SIGNAL_SET_MODBUS_COMM_ID	UINT16	N/A	0 ~ 255	Modbus ID	Read /Write
0x10C1	4289	PFC_IO_SIGNAL_SET_MODBUS_COMM_B AUDRATE-High	UINT32	BPS	1200 :1200bps 2400 :2400bps 4800 :4800bps 9600 :9600bps 19200 :19200bps 38400 :38400bps 57600 :57600bps	BaudRate	Read /Write
0x10C2	4290	PFC_IO_SIGNAL_SET_MODBUS_COMM_B AUDRATE-Low					
0x10C3	4291	PFC_IO_SIGNAL_SET_MODBUS_COMM_D ATA_BITS	UINT16	N/A	0x0000:8 0x1000:9	Data bit	Read /Write
0x10C4	4292	PFC_IO_SIGNAL_SET_MODBUS_COMM_ST OP_BITS	UINT16	N/A	0x0000:1 0x2000:2	Stop bit	Read /Write
0x10C5	4293	PFC_IO_SIGNAL_SET_MODBUS_COMM_P ARITY	UINT16	N/A	0x0000:None 0x0400:even parity 0x0600:uneven parity	Parity	Read /Write
0x10C6	4294	PFC_LOAD_DEFAULT_SETTING	UINT16		0: Cancel 1: Comfirm	Default value	Read /Write

0x10C9	4297	PFC_SIMULATION_FUNC_STATE	UINT16	N/A	0:None 1: Flow rate 2: Flow capacity 3: Current output 4: Frequency output 5: Output1 status 6: Output2 status	Simulation fuction select	Read /Write
0x10CA	4298	PFC_SIMULATION_FLOW_SPEED-High	FLOAT64	m/s	-10.000~10.000	Simulation of flow rate	Read /Write
0x10CB	4299	PFC_SIMULATION_FLOW_SPEED+1					Read /Write
0x10CC	4300	PFC_SIMULATION_FLOW_SPEED+2					Read /Write
0x10CD	4301	PFC_SIMULATION_FLOW_SPEED-Low					Read /Write
0x10CE	4302	PFC_SIMULATION_FLOW_RATE-High	FLOAT642	Rate Unit	+0.0000 ~ Caliver(m)^2 *7.85	Simulation of flow capacity	Read /Write
0x10CF	4303	PFC_SIMULATION_FLOW_RATE+1					Read /Write
0x10D0	4304	PFC_SIMULATION_FLOW_RATE+2					Read /Write
0x10D1	4305	PFC_SIMULATION_FLOW_RATE-Low					Read /Write
0x10D2	4306	PFC_SIMULATION_OUTPUT_CURR-High	FLOAT32	mA	3.6~22	Simulation of current output	Read /Write
0x10D3	4307	PFC_SIMULATION_OUTPUT_CURR-Low					Read /Write
0x10D4	4308	PFC_SIMULATION_OUTPUT_FREQ	UINT16	Khz	0.002~8Khz	Simulation of frequency output	Read /Write
0x10D5	4309	PFC_SIMULATION_OUTPUT_1_STATUS	UINT16	N/A	0: OPEN 1: CLOSED	Simulation of output1 status	Read /Write
0x10D6	4310	PFC_SIMULATION_OUTPUT_2_STATUS	UINT16	N/A	0: OPEN 1: CLOSED	Simulation of output2 status	Read /Write

0x10DE	System specific setting		Data Type	Unit	Range	Definition	Authority
0x10DE	4318	PFC_SAVE_SYSTEM_VAR_TO_EEPROM	UINT16	N/A	0: none 1: Input	Input USER EEPROM	Read /Write
0x10DF	4319	PFC_ENG_MODE_SAVE_SETTING	UINT16	N/A	0: none 1: Input	Input FACTORY; Set EEPROM	Read /Write
0x10E0	4320	pfc_auto_set_excition_freq_flag	UINT16	N/A	0: Off 1: On	Auto input excitation frequency accoring to frequency and pipe size	Read /Write



EPD36 衛生接續電磁式流量計

產品操作手冊



桓達科技股份有限公司

23678 新北市土城工業區自強街 16 號

電話：886-2-22696789

網址：<http://www.fine-tek.com>

傳真：886-2-22686682

E-mail:info@fine-tek.com

目 錄

1. 閱讀標示	3
2. 產品保證	4
2.1 新品保固	4
2.2 維修保固	4
2.3 服務網絡	5
3. 產品檢查	6
3.1 物品核對	6
3.2 安全查驗	6
4. 概述.....	6
5. 產品特點	7
6. 適用範圍	7
7. 環境條件	7
8. 工作原理	8
9. 技術性能	9
9.1 執行標準	9
9.2 基本參數和性能指標	9
10. 外型尺寸	11
10.1 Tri-Clamp.....	11
11.安裝.....	12
11.1 保證電磁流量計測量精度的必要條件：	12
11.2 安全措施	12
11.3 安裝前的檢查	12
11.4 吊裝	13
11.5 正確安裝	13
11.6 管道上安裝注意事項	15
11.7 接地要求	16
11.8 改變傳送器盒的方向	16

12. 接線與使用	17
12.1 接線	17
13. 送電前的檢查	18
14. 參數功能說明	18
14.1 設定選單流程說明	18
14.1.1 顯示介面功能.....	19
14.1.2 參數設定狀態時的鍵功能.....	19
14.2 各參數設定功能說明.....	20
14.3 各參數設定範圍說明.....	28
15. 產品選型	30
16. 運輸與貯存	31
17. 故障檢查與維修	32
18. MODBUS 通訊協定	34

1. 閱讀標示

感謝您購買本公司桓達科技的產品，此操作說明書是針對產品的特性、動作原理、操作和維修方式，還有使用注意事項等內容來說明，可讓使用者充分瞭解產品的正確使用方法，避免發生設備損壞或操作者受傷等危險狀況。

- 使用本產品前，請完整、仔細的閱讀本操作手冊。
- 若本操作手冊無法提供您所要的需求時，請與本公司聯絡。
- 本操作說明書的內容，會依照版本的更新而有所不同，將會上傳於本公司網站上，提供使用者下載。
- 請不要自行拆開或維修，這意味著您將失去保固資格。請將產品寄回本公司維修和校準，或與本公司聯絡。
- 警告符號說明：



提示危險→表示若操作錯誤會有致命和重大災害的危險。



提示注意→表示若操作錯誤會有一定程度的傷害和設備的損壞。



提示電擊→表示可能會觸電的警告。



提示火災→表示可能會發生火災的警告。



提示禁止→表示禁止的錯誤動作事項。

2. 產品保證

2.1 新品保固

- 本公司產品於交貨日算起十二個月內，在符合保固條件之下發生故障，可不收檢測、零件、維修等費用。
- 產品運送過程導致新品瑕疵而非人為故障，可於7日內向本公司更換。
- 產品故障需寄回原廠維修時，請將產品整組寄回，勿自行拆卸部品，並且包裝請務必完善，避免運送損毀，造成更大的損失。
- 產品保證僅針對正常使用客戶，如有特殊應用、不正常使用及超量使用者，則不在此保證範圍內。
- 在以下狀況下發生故障，將不具有保固條件，需酌收檢測、零件、維修等費用：
 - 產品整機或零件超過保固期限。
 - 未依操作手冊使用或未依說明書上之使用環境，所致之故障毀壞。
 - 產品之毀損係受不可抗力(天災、水災、火災、地震、雷擊、颱風等)，人為破壞(刮傷、摔傷、卡榫斷裂、敲打、破裂、重擊等)，人為疏失(使用不合適的電壓、高濕、進水、汙漬、腐蝕、遺失、未妥善保管等)或其他非正常因素所致者。遭遇天災地變之不可抗拒之外力的情況下，所造成的故障。
 - 客戶擅自或使第三人安裝、添附、擴充、修改、修復非本公司授權或認可之零件所致之毀壞。
 - 產品標籤資訊不符或破損不清楚而無法確定產品序號時。

2.2 維修保固

本公司對於產品維修後，針對維修部份提供**六個月**保固期，在此期間內若同一零組件再發生相同故障時，即可享有免費維修服務。

2.3 服務網絡

公司	地址	電話	傳真
臺北總公司 (臺灣)	23678 新北市土城工業區自強街 16 號	+886 2-2269-6789	+886 2-2268-6682
台中營業處 (臺灣)		+886 4-2337-0825	+886 4-2337-0836
高雄營業處 (臺灣)		+886 7-333-6968	+886 7-536-8758
上海凡宜科技電子 有限公司(中國)	201109 上海市閔行區顧橋鎮都會路451號	+86 021-64907260	+86 021-6490-7276
Aplus FineTek Sensor Inc. (美國子公司)	355 S. Lemon Ave, Suite D, Walnut, CA 91789	1 909 598 2488	1 909 598 3188
Finetek Pte Ltd. (新加坡分公司)	37 Kaki Bukit Place, Level 4 Singapore 416215	+65 6452-6340	+65 6734-1878
FineTeK GmbH (德國分公司)	Bei den Kämpen 26 21220 Seevetal-Ramelsloh, Germany	+49 (0) 4185 8083 0	+49 (0) 4185 8083 80
PT. FineTek Automation Indonesia (印尼分公司)	PERGUDANGAN TUNAS BITUNG JL. Raya Serang KM. 13,8, Blok C3 No. 12&15, Bitung Cikupa, Tangerang 15710	+62 021-2958-1688	

3. 產品檢查

3.1 物品核對

- 流量計1組
- 操作說明書1份
- 產品檢驗單1份

3.2 安全查驗

- 拆封前請檢查外包裝有無變形或破損，並拍照存證作為事後補償依據
- 拆封後請檢查內容物有無變形或破損及一切品質問題，並拍照存證作為事後補據
- 開箱後請立即核對內容物是否與訂購內容相符，數量是否正確
- 若有以上異常狀況請於貨到7日內連絡本公司(連同照片)，否則恕不無償給予補換貨或維修

4. 概述

本公司電磁流量計，採用穩定性高的線圈激磁方式，其穩定性較傳統的生磁方式高。產品經過嚴苛的震動和抗雜訊測試後都能很穩定的工作，對於工業現場環境的複雜性有良好的耐受度，在實際的應用中有著更長的产品壽命。

電磁流量計從開始發展到今天，持續不斷的被改良，常被廣泛的應用到各類的工業流體管道的監控中，其中包含發電、水處理、食品、醫藥、船舶、染整、半導體製程等不勝枚舉。由於電磁流量計的原理單純，適用範圍廣，只要適當的選型並與流體性質配合便能良好的應用在各類的環境之中。

5. 產品特點

- 測量時不受液體密度、粘度、溫度、壓力及導電率等變化而影響測量結果
- 測量管內只有兩個量測點，沒有阻流件及活動件，故不會造成壓力損失及堵塞的情況
- 可測試導電液體及含微量固體顆粒之流體流量
- 安裝時所需的直管段僅需流量計上游前 5D 及下游 2D，不需複雜的管路設計
- 測量的量程比可 1:100，尤其在小流量測量時精度高
- 具備自我診斷功能，可自我偵測激磁訊號、測量管是否為空管、電極是否汙損
- 內襯材質為 PFA
- 最高允許流體溫度可達 150°C
- 流量轉換器設定簡單、功能性強
- 支援參數修改紀錄、開關機紀錄(選購)
- 選單支援權限管理(選購)

6. 適用範圍

- 導電率：> 5 μ S/cm
- 流體性質：液體、含少量固體顆粒之液體。
- 應用產業：發電、水處理、食品、醫藥、船舶、染整、半導體製程

7. 環境條件

- 環境溫度：-40°C ~ 70 °C
- 相對濕度：5% ~ 95% of RH, 無凝結水
- 大氣壓力：86 ~ 106 KPa
- 電源：24 VDC

8. 工作原理

電磁流量計動作原理是基於法拉第電磁感應定律。當導體在磁場內運動，在與磁場方向、運動方向相互垂直方向的導體兩端，會有感應電動勢產生。電動勢的大小與導體運動速度和磁感應強度大小成正比。

在<圖一>中，當導電液體以平均流速 V (m/s)，通過裝有一對測量電極的一根內徑為 D (m) 的絕緣管子流動時，並且該管子處於一個均勻的磁感應強度為 B (T) 的磁場中。那麼，在這對電極上就會感應出垂直於磁場和流動方向的電動勢 (E)。

由電磁感應定律， E 可寫作 (1) 式：

$$E = kB \cdot D \cdot V \text{ (V)} \dots\dots\dots (1)$$

式中 k 是比例係數。

體積流量可以寫作

$$q_v = \frac{\pi D^2}{4} V \text{ (m}^3/\text{s)} \dots\dots\dots (2)$$

由公式 (1) 和 (2) 可得到：

$$q_v = \frac{\pi D E}{4k B} \text{ (m}^3/\text{s)} \dots\dots\dots (3)$$

因此電動勢可表示為：

$$E = \frac{4kB}{\pi D} q_v \text{ (V)} \dots\dots\dots (4)$$

當 B 是個常數時，公式 (3) 中

$$\frac{\pi D}{4k B} = A$$

，公式 (3) 改寫為：

$$q_v = AE \text{ (m}^3/\text{s)} \dots\dots\dots (5)$$

可見，流量 q_v 與電動勢 E 成正比。

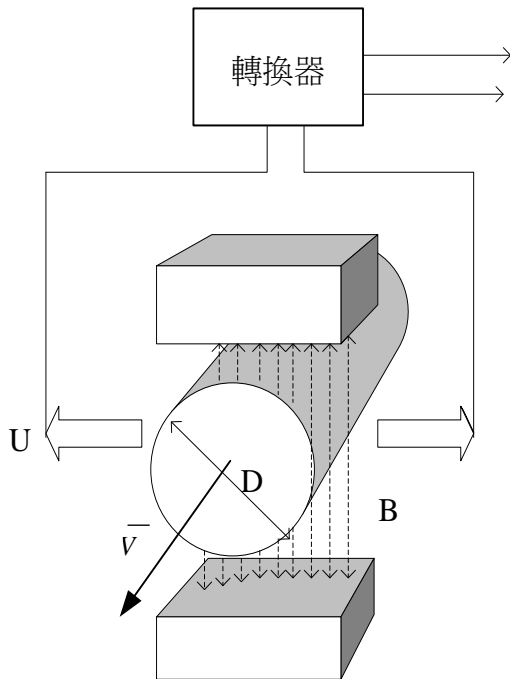

<圖一>

9. 技術性能

9.1 執行標準

IEC 60068-2-3

IEC 61326-1

IEC 60092-504

JIS B2220

ANSI B16.5

EN 61326-1:2013

EN 55011:2009/A/:2010

ISO 4064-1

JIS B7554-1997

DIN 25 Series

9.2 基本參數和性能指標

9.2.1 產品技術規格表

項目	EPD36
螢幕	LCM 128*64 畫素背光型
按鍵	3 鍵式操作
通訊介面	RS-485 (Modbus)
精確度	±0.5% of reading@1m/s(0.2% optional)
介質溫度	-20 ~ 150°C(PFA 內襯)
環境溫度	-40 ~ 70°C*
流體導電度	>5 uS/cm
量測範圍	0.1m/s ~ 10m/s
電流輸出精度	0.1% of Pulse Output Accuracy,溫度係數(100ppm/°C)
耐壓	10 Kg/cm ²
電流輸出模式	主動
類比輸出	4 ~ 20 mA
電流輸出最大負載	< 700 Ω
警報電流	3.6 mA 或 22 mA
頻率輸出範圍	2 ~ 8KHz
Pulse 寬度	自動 (脈波寬度 50%)
Pulse 模式	隔離式 NPN 晶體輸出 32Vdc/200mA
時間常數	1~100 s
控制輸出(DO)	隔離式 NPN 晶體輸出 32Vdc/200mA; 2-CH
控制輸入(DI)	乾接點 ON< 200Ω ; 1,000Ω< OFF ; 1-CH
資料紀錄(選購)	500 筆資料,含萬年曆(內建電池壽命 6 個月)
鮑率	1200 ~ 57600 bps
防護等級	IP67 / NEMA 4X
接線盒材質	鋁合金
輸入電源	DC 24V
消耗功率	< 10W
入線口規格	1/2" NPT
激磁模式	Pulse DC
震動規範	MIL-STD-202G-201A:2002
EMC 規範	IEC/EN 61326-1 Class A table2

*LCM 低於-20°C時無法顯示

9.2.2 各管徑建議流量範圍

管徑 (mm)	流量範圍 (m ³ / h)	
	流速 0.1~1.0 m/s	流速 1.0~10 m/s
15	0.06~0.64	0.64~6.4
25	0.17~1.77	1.77~17.7
40	0.45~4.5	4.5~45.2
50	0.71~7.1	7.1~71

9.2.3 內襯材料

內襯材料	主要性能	適應範圍
PFA	1. 化學性能穩定，能耐各種酸、鹼、鹽溶液和各種有機溶劑。不耐三氟化氯(ClF ₃)，高溫三氟化氯，高流速液氧，臭氧的腐蝕。 2. 耐磨性能一般。	1. -20~150 °C 2. 濃酸、鹼等強腐蝕性介質。

9.2.4 電極材料

電極材料	耐蝕性能
不鏽鋼(316L)	用於水、污水或無機、有機腐蝕性介質。

9.2.5 外殼防護等級

IP67

10. 外型尺寸

衛生接續型

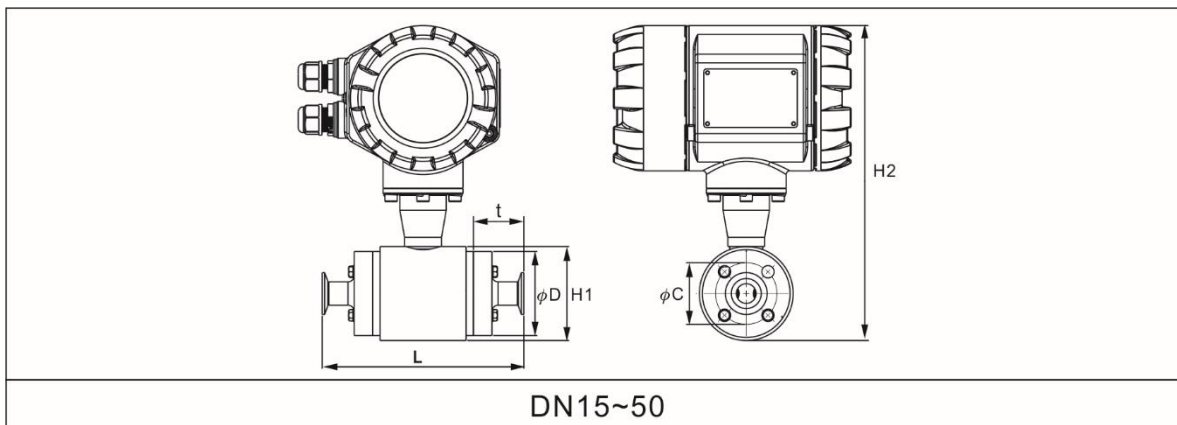

10.1 Tri-Clamp

接續規格		Tri-Clamp			
公稱通徑(mm)		15	25	40	50
內襯材質		PFA			
長度	L	164	164	258.6	258.6
外徑	φD	68.3	81.1	106.3	106.3
PCD	φC	50	60	83	83
法蘭厚度	t	41	41	61.5	61.5
螺絲孔數量	N	4	4	4	4
傳感器高度	H1	76.3	89.1	114.3	114.3
總高度	H2	256	270	294	294
重量(Kg)	---	4.9	5.7	8.6	9.1

接續尺寸規格

Tri-Clamp	DN	di (mm)	G (mm)
	15	15.8	25
	25	22.1	50.5
	40	34.8	50.5
	50	47.5	64

11. 安裝

流量計的設計、試驗和供電均有相關規定，用戶必須嚴格遵守說明，以確保流量計的安全操作及正常運作。

11.1 保證電磁流量計測量精度的必要條件：

- 被測液體必須具有導電性
- 被測液體必須能充滿管道
- 被測液體必須均勻，以保證避免電導率的不均勻性（會產生嚴重干擾），如需動態加入化學物質，應在流量計下游處加入
- 電磁流量計系統必須良好接地，尤其在塑膠管道中一定要加裝接地環並實值接地
- 流量計入口直管段至少 5 倍 D(測量管道內徑)，出口直管段至少 2 倍 D
- 在流量計附近應避免強電磁場干擾；避免安裝在大型電機或變壓器等設備附近

11.2 安全措施

為保障人身和設備的安全，須遵守以下事項：

- 在選擇位置和安裝流量計之前，必須認真閱讀完本說明書有關部分，同時要考慮流量計、相關設備和機身環境的安全要求
- 應由具備一定流量計知識的人員進行流量計的安裝和維修
- 正確安裝流量計感測器及配管，保證密封安全可靠，液體壓力不得超過流量計規格上所能承受的最高工作壓力
- 採取適當措施，防止觸電事故
- 流量計的吊裝設備應符合安全規定

11.3 安裝前的檢查

- 檢查法蘭、內襯、外殼和出線套有無損傷
- 打開盒蓋、檢查接線印刷電路板有無鬆動或損壞
- 檢查銘牌中型號編碼與訂貨編碼是否相符

11.4 吊裝

流量計應採用正確吊裝方法進行吊裝，吊裝設備的安全載荷及防護措施應符合有關規定。禁止在傳送器箱體（一體式流量計）或接線盒（分離型流量計）處用繩拴起吊流量計。

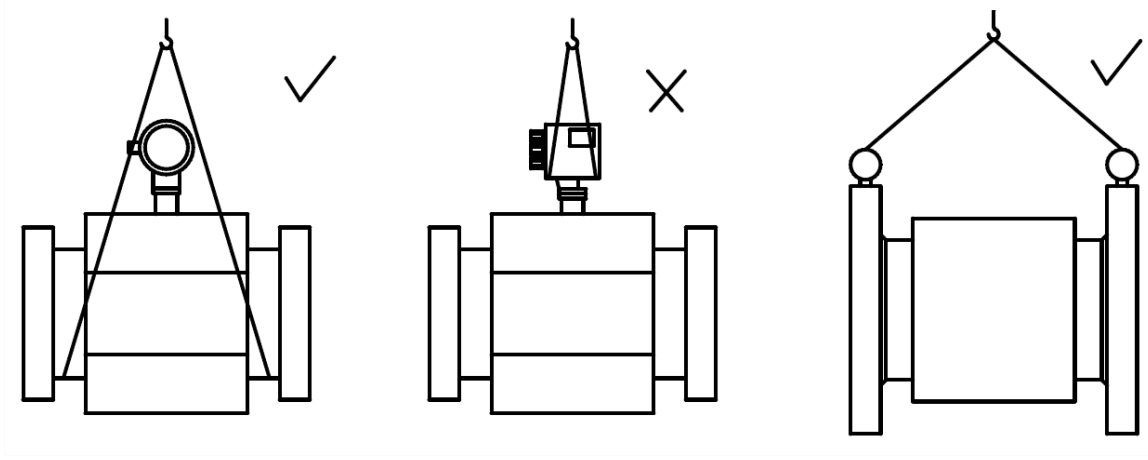

11.5 正確安裝

正確地選擇安裝點和正確安裝流量計都是非常重要的環節，若在安裝環節失誤，輕者影響測量精度，重者會影響流量計的使用壽命，甚至會損壞流量計。

選擇安裝位置時需特別注意

- a. 測量電極的軸線必須近似於水平方向（與水平線夾角一般為 10° 以內）。

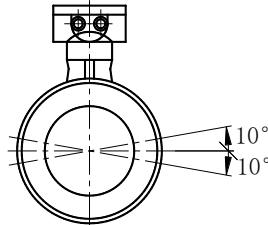

- b. 測量管道內必須完全充滿液體。
- c. 流量計的前方最少要有 $5 \times D$ (D 為流量計內徑) 長度的直管段，後方最少要有 $2 \times D$ (D 為流量計內徑) 長度的直管段。

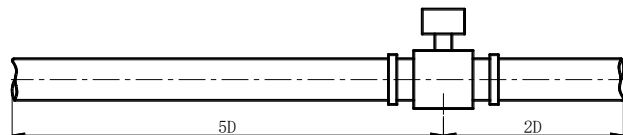

- d. 流體的流動方向和流量計的箭頭方向一致。
- e. 請避免在管道內出現真空現象，會損壞流量計的內襯。
- f. 在流量計附近應無強電磁場，流量計安裝場所的磁場強度應小於 $400A/m$ （避免安裝在大型電機或變壓器等設備附近）。

- g. 在流量計附近應有充裕的空間，以便安裝和維護。
- h. 若測量管道有振動，在流量計的兩邊應有固定的支座。
- i. 測量不同介質的混合液時，混合點與流量計之間的距離最少要有 $30 \times D$ (D 為流量計內徑長度)。
- j. 為方便今後流量計的清洗和維護，應安裝旁通管道。

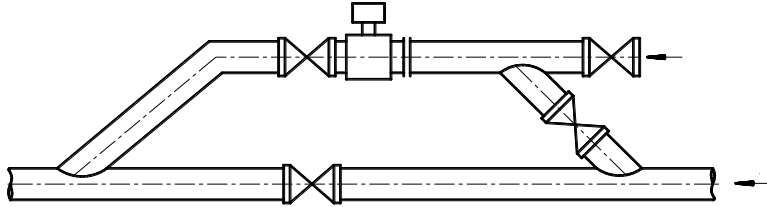

- k. 安裝 PTFE 內襯的流量計時，連接兩法蘭的螺栓應注意均勻擰緊，否則容易壓壞 PTFE 內襯，盡可能使用扭力扳手。
- l. 流量計應避免強烈振動和過大的溫度變化，同時要防止腐蝕性液體的對流量計造成損害。
- m. 如果安裝地點易受陽光曝曬，應增加遮陽設施。
- n. 安裝感測器時，應盡可能的使測量管與製程管道位於同一個軸線上。
對 DN50 及以下公稱通徑的感測器，其軸線偏離不超過 2mm。DN65~DN150 其軸線偏離不超過 3mm， \geq DN200 其軸線偏離不超過 4mm。
- o. 法蘭之間加裝的墊片，應有良好的耐腐蝕性能，該墊圈不得伸入管道內部，阻礙流體流動。
- p. 緊固流量計螺栓、螺母，其螺紋應完整無損，潤滑良好。應依據法蘭尺寸、力矩大小採用力矩扳手緊固螺栓。
- q. 在感測器鄰近管道進行焊接或火焰切割時，要採用隔離措施，防止襯裏受熱，且必須確認流量計未通電運行，防止損壞流量計。

11.6 管道上安裝注意事項

流量計安裝時，必須遵守以下安裝示意圖例，以確保流量計可以保證液體永遠充滿管道：(以下圖例僅為典型說明，並未包含全部可行的安裝方式，使用者應依實際工況進行安裝位置判斷。)

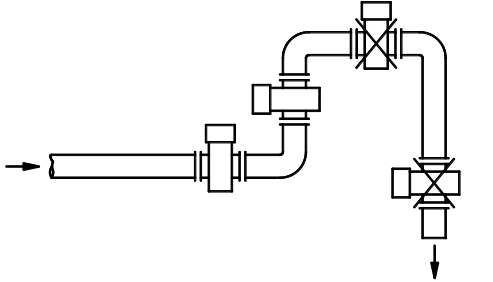
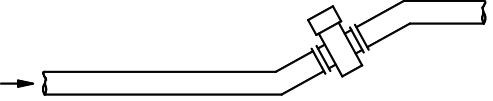
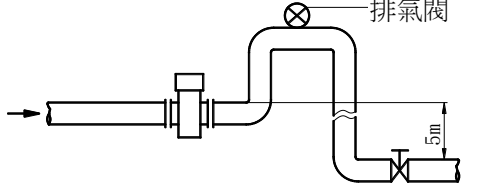
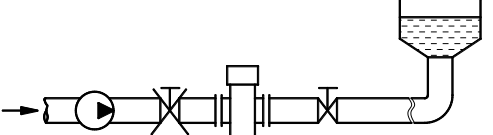
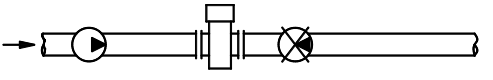
序號	圖例	說明
1		<ul style="list-style-type: none"> ■ 應安裝在水平管道較低處和垂直向上處。 ■ 避免安裝在管道的最高點和垂直向下處。
2		<ul style="list-style-type: none"> ■ 應安裝在管道的上升處。
3		<ul style="list-style-type: none"> ■ 若管道落差超過 5m，在傳感器的下游安裝排氣閥 ■ 傳感器的下游應有一定的背壓。
4		<ul style="list-style-type: none"> ■ 應在傳感器的下游安裝控制閥和切斷閥，而不應安裝在傳感器上游。
5		<ul style="list-style-type: none"> ■ 傳感器絕對不能安裝在幫浦的進口處，安裝在幫浦的出口處。

11.7 接地要求

電磁流量計的接地是非常重要的，若接地不良，無法正常工作，感測器和傳送器部分應有良好的單獨接地線（銅芯截面積為 1.6mm^2 ），接地電阻 $<10\Omega$ 。

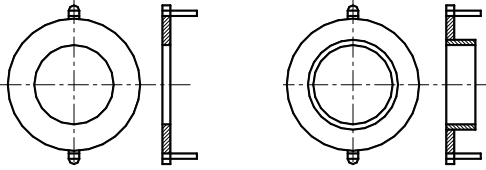
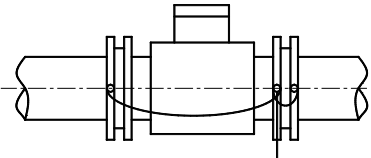
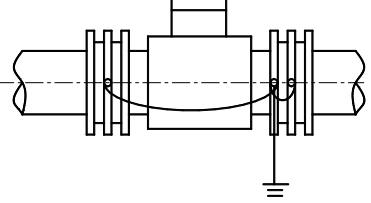
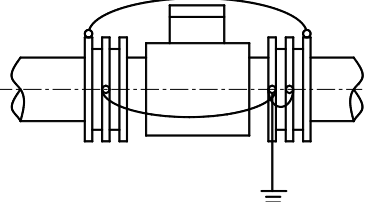
	圖例	說明
接地環		<ul style="list-style-type: none"> ■ 若與感測器連接的管道是絕緣性的，則需用接地環 ■ 應選擇其材質和電極的材質一樣，避免被液體。 ■ 若被測介質是磨損性的，應選擇帶頸接地環。
接地方式		<ul style="list-style-type: none"> ■ 流量計在金屬管道上的安裝，金屬管道內壁沒有絕緣塗層。
		<ul style="list-style-type: none"> ■ 流量計在塑膠或內壁有絕緣塗料、油漆、內襯等管道上安裝時，應在傳感器的兩端安裝接地環。
		<ul style="list-style-type: none"> ■ 流量計在陰極保護管道上安裝，防護電解腐蝕的管道一般在其壁和外壁是絕緣的，安裝時需注意接地環和管道上的法蘭應絕緣。

11.8 改變傳送器盒的方向

傳送器盒可以根據需要作四個不同方向的轉變。

a. 一體型流量計的傳送器盒方向的改變

- 取下固定傳送器的 4 個六角螺絲。
- 將傳送器盒轉到理想的方向，旋轉時注意內部連接線。
- 重新固定傳送器。

12. 接線與使用

12.1 接線

12.1.1 接線注意事項

- 電源線建議選用二芯絕緣橡皮電纜線，線材外徑應大於 10mm。
- 當為交流供電時，L1 應接“火線”
- 一般 24VDC 電源供電的情況下，電纜線的電阻應不大於 10Ω。
- 所有的端子台接線應夾一字端子，並作好絕緣；應避免電線直接伸入端子台。
- 電流輸出端子出線電纜總阻抗不得大於規格所標稱的阻抗。
- 脈波或頻率輸出一般為 NPN 晶體輸出，需外接電源。

12.1.2 打開背後外殼蓋，可看見如下圖所示接線端子

DC 24V

數位輸出 1		RS-485 通訊		數位輸入			
DO1-	DO1+	D-	D+	DI-	DI+		
	V+	V-		P-	P+	mA-	mA+
	DC24V			電壓脈波輸出		4-20mA 輸出	

13. 送電前的檢查

1. 流量計在運輸和安裝中有無損傷
2. 使用電源電壓同銘牌電壓是否相符
3. 使用正確流量值的保險絲
4. 流量計正確接地
5. 打開管道閥門使液體充滿管線系統，應注意排除洩漏和系統內的殘留氣體
6. 接通流量計電源，通電預熱 10 分鐘即可正常工作

14. 參數功能說明

14.1 設定選單流程說明

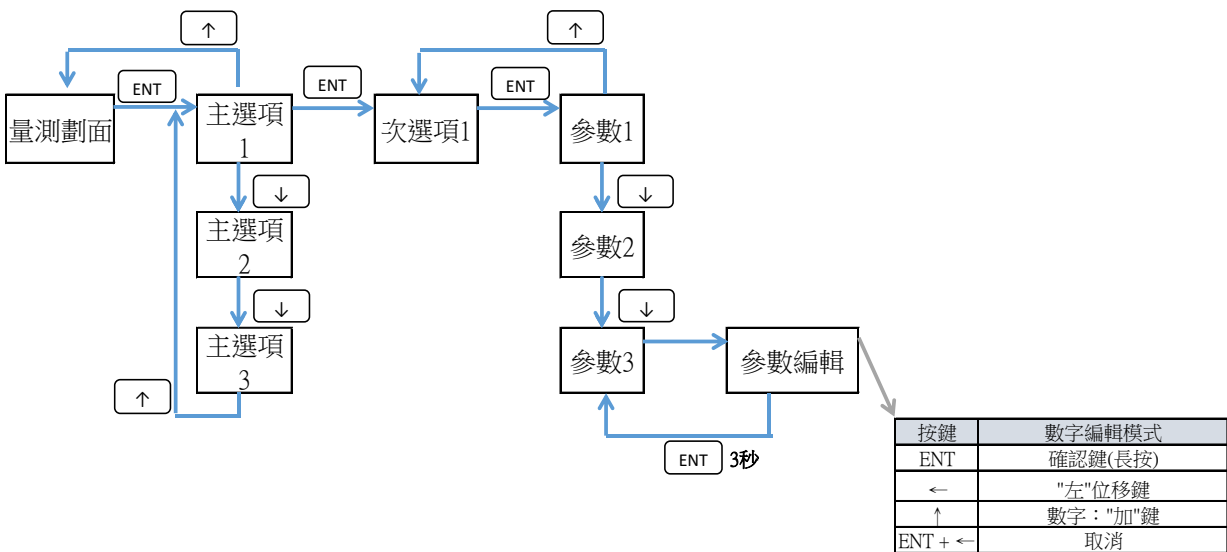

14.1.1 顯示介面功能

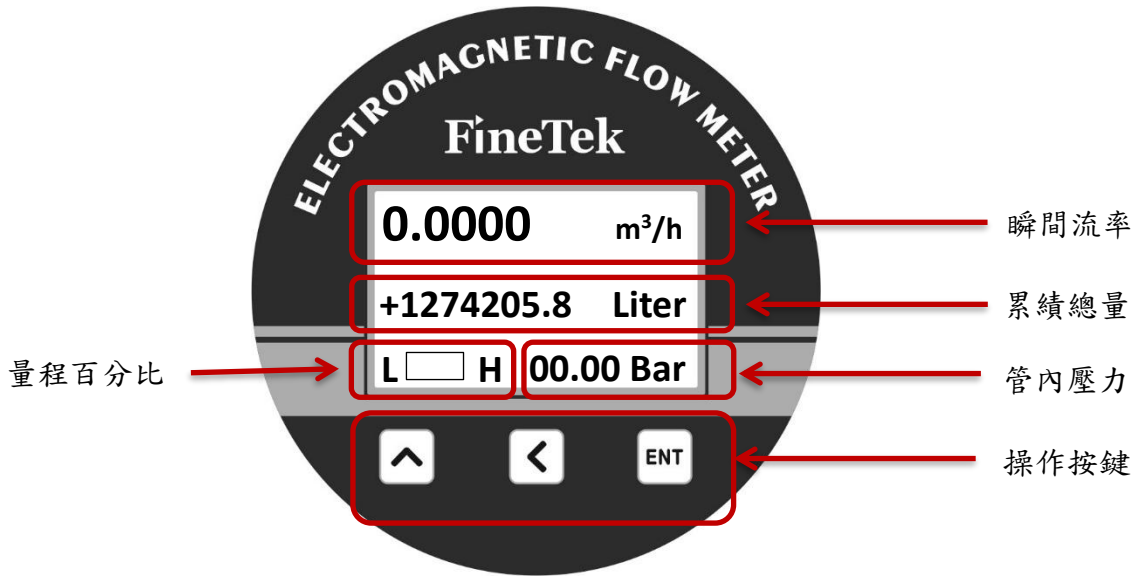

14.1.2 參數設定狀態時的鍵功能

			參數設定頁面		
按鍵	量測主畫面	選單模式	Read Only	數字編輯模式	清單編輯模式
ENT	進入選單	進入次選單		確認鍵(長按)	確認鍵(長按)
←		回上層	回上層	"左"位移鍵	回上層
↑		次選單項目【下】		數字："加"鍵	選項：下翻頁
ENT+ <				取消	

14.2 各參數設定功能說明

主選項	次選項	說明	單位	出廠值	設定值範圍	功能描述
快速設定(0)	裝置位號 (1.1)	N/A				此區參數是從標準選單中取出之捷徑
	流量零點調整 (2.1)	N/A				
	流率滿量程 (1.5)	N/A				
	瞬時流率單位 (1.4)	N/A				
	低流量屏避 (2.4)	N/A				
	輸入訊號平均時間 (3.1)	N/A				
	脈波單位設定 (3.3)	N/A				
	總量重置設定 (1.9)					

主選項	次選項	說明	單位	出廠值	設定值範圍	功能描述
基礎設定(1)	裝置位號 (1.1)	N/A	none	00001	00001~65535	客戶端工廠管理用 tag number
	量測液體類型 (1.2)	N/A	-	水	水(Water)	設定量測液體類型種類
	流量計口徑 (1.3)	10~100 mm(1.3.1)	mm	actual	10,15,25,32,40,50,65,80,100	設定流量計公稱通徑， 可計算流量量程
		125~500 mm(1.3.2)			125,150,200,250,300,350,400,450,500	
	瞬時流率單位 (1.4)	N/A	-	m ³ /h	L/(s,min,h), m ³ /(s,min,h), gal/(s,min,h), kg(s,min,h), Ton(s,min,h) (若選重量單位，流量自動和 密度相乘) "L/s","L/m","L/h", "m ³ /s","m ³ /m","m ³ /h", "gal/s","gal/m","gal/h", "kg/s","kg/m","kg/h","Ton/s", "Ton/m","Ton/h","m ³ /d"	瞬時流量自動以此設定 單位顯示
	流率滿量程 (1.5)	N/A	=流率單位	(5m/s) x (口徑 mm/2) ² x pi x 流率單 位	(0.1 ~ 10.0m/s) x (口徑 mm/2) ² x pi x 流率單位 (000.00)	此量程設定直接對應到 4-20mA 輸出及頻率輸 出值
	流體方向 (1.6)	N/A	dir	順向 (Forward)	順向,逆向	可選擇流體的流動方向
	總量累積單位 (1.7)	N/A	-	Liter	Liter,gal, m ³ ,kg,Ton	總量流量自動以此設定 單位顯示
	總量累積模式 (1.8)	N/A	none	順向	順向,逆向,雙向	Σ+正向流測量,Σ-反向 流測量,ΣΔ雙向流測量 (Δ= 正流 - 反流)
總量重置設定 (1.9)	N/A	none	Cancel	否,是	將目前顯示的總累積量 清除。	

主選項	次選項	說明	單位	出廠值	設定值範圍	功能描述
進階設定 (2)	流量零點調整 (2.1)	AUTO	m/s	Actual	-0.5000~+0.5000	在滿管無流量時的零點 流量補償
		MANUAL				
	流量係數 K (2.2)	N/A	none	1.000	0.000~3.000	流量傳感器特徵參數， 真實值 = 測量值 x k
	密度 (2.3)	N/A	g/cm ³	1.0000	0.0001~9.9999	質量流量=體積流量*密度
	低流量屏避 (2.4)	N/A	%	0.5	0.00~100.00	當管路內有微流或振動 時，找低流顯示屏避 (判斷流率大於該值才顯 示並累積)
	順向總量起始值 (2.5)	N/A	=總量累積單 位	0	0~9999999999	初始化目前的正向累積 總量
	反向總量起始值 (2.6)	N/A	=總量累積單 位	0	0~9999999999	初始化目前的正向累積 總量

主選項	次選項	說明	單位	出廠值	設定值範圍	功能描述
輸出入訊號設定(3)	輸入訊號平均時間 (3.1)	N/A	second(s)	3	0~100	將實際流量做平均值輸出
	脈波輸出模式 (3.2)	N/A	none	Pulse NO	Pulse NO, Pulse NC, Frequency	Pulse 輸出接點的初始狀態，或用頻率來表示流率(如果選頻率,依流率表示),Pulse No,Nc 為總量輸出的高低電位狀態
	脈波單位設定 (3.3)	N/A	Unit/pulse	0.1 L	0.001~100(L,gal,m ³ ,g,kg,Ton) L/pulse,gal/pulse,m ³ /pulse,g/pulse,kg/pulse,Ton/pulse	可設定每個 pulse 所代表的流量
	頻率設定 (3.4)	N/A	Hz,kHz	2K	1~8K (00.000)	在設定的流率滿量程下的最高輸出頻率值
	電流輸出模式設定 (3.5)	N/A	none	4-20	4-20,0-20	選擇電流輸出模式
	電流輸出 4mA 微調 (3.6)	N/A	count	0	-5000~5000	可調整 4mA 輸出的基準值
	電流輸出 20mA 微調 (3.7)	N/A	count	0	-5000~5000	可調整 20mA 輸出的基準值
	輸入 1 接點功能 (3.8)	N/A	N/A	None	None,總量重置	輸入接點動作時所執行的功能。
	輸入 1 接點型式 (3.9)	N/A	N/A	NO	NO,NC	設定輸入接點的原始狀態，可能 NO 或 NC
	濾波視窗變化率 (3.10)	N/A	m/s	1	00.000~10.000	降低流量突波變化準位設定
	濾波視窗權重 (3.11)	N/A	%	10	0~100	降低流量突波變化
	中位數波視窗 (3.12)	N/A	%	Enable	Dusable,Enable	降低流量測量時雜訊的影響

主選項	次選項	說明	單位	出廠值	設定值範圍	功能描述
警報設定(4)	流率上限 (4.1)	N/A	瞬時流率 單位	該口徑最大值	0~±至流率上限值(000.00)-	設定流率超過此設定時，則被觸發報警
	流率下限 (4.2)	N/A	瞬時流率 單位	該口徑最小值	0~±至流率上限值(000.00)-	設定流率低於此設定時，則被觸發報警
	空管檢測 (4.3)	N/A	N/A	Enable	Disable,Enable	當電導率低到某一程度即判斷為空管狀態
	輸出 1 功能 (4.4)	N/A	N/A	流量上限警報	None,流量上限警報,流量下限警報,空管警報,系統異常	選擇輸出 1 接點的功能
	輸出 1 接點型式 (4.5)	N/A	N/A	NO	NO,NC	設定警報接點的原始狀態，可能 NO 或 NC
	輸出 2 功能 (4.6)	N/A	N/A	流量下限警報	None,流量上限警報,流量下限警報,空管警報,系統異常	選擇輸出 2 接點的功能
	輸出 2 接點型式 (4.7)	N/A	N/A	NO	NO,NC	設定警報接點的原始狀態，可能 NO 或 NC
	警報電流功能 (4.8)	N/A	N/A	None	None,空管警報,系統異常	選擇電流警報的功能
	警報電流設定 (4.9)	N/A	mA	3.6	3.6,3.8,20.5,22	設定當警報發生時之輸出電流值
	溫度警報 (4.10)	N/A	N/A	1	0: 關, 1:開	設定當溫度過高時,觸發警報

主選項	次選項	說明	單位	出廠值	設定值範圍	功能描述
系統設定 (5)	系統語言 (5.1)	N/A	N/A	English	English, 繁中, 簡中	系統顯示語言
	系統資訊 (5.2)	測量管狀態	N/A	Actual	正常/空管	檢測目前量測管內液體是否溢過兩電極測量點
		目前流速	m/s	Actual	N/A	測量目前流體速度的真實值
		液體阻抗	kΩ	Actual	N/A	測量目前流體電阻值真實值
		系統狀態碼	N/A	Actual	0000 0000 ~ FFFF FFFF	顯示目前系統狀態代碼
	自我測試 (5.3)	N/A	N/A	取消	正常, 電路異常(Device 周邊溝通與確認), 激磁異常, 環境溫度過高, 電極汙損 警示訊息無中文	正常: 系統自我檢測無發現任何異常現象 電路異常: 板溫過高/過低、I/O 失效、無法檢知訊號 激磁異常: 激磁電流無法檢知或電流異常 環境過高: 環境溫度超出可允許範圍 電極汙損: 電極嚴重被覆蓋非導電性物質
	類比輸入 設定(5.4)	4mA 顯示值	N/A	0000	0~9999	設定輸入電流的對應顯示值 Scale Low
		20mA 顯示值	N/A	100	0~9999	設定輸入電流的對應顯示值 Scale High
		4-20mA 輸入 單位	N/A	Kpa	None, Kpa, Mpa, Psi, Bar, °C, °F	輸入電流對應顯示單位設定
		小數點位數	N/A	1	0~3	設定小數點位數

Modbus 通訊 (5.5)	Modbus ID(2.13.1)	N/A	1	1~255	基本通訊設定
	BaudRate (2.13.2)	BPS	9600	1200,2400,4800,9600,19200,38400,57600	
	Data bit(2.13.3)	N/A	8	8,9	
	Parity (2.13.4)	N/A	none	none,odd,even	
	Stop bit(2.13.5)	N/A	1	1,2	
恢復出廠設 定值 (5.6)	N/A	N/A	取消	取消,確認(Cancel, Accept)	
市電頻率 (5.7)	N/A	Hz	50	50,60	選擇接入之市電頻率
LCM 亮度 (5.8)	N/A	N/A	32	15~40	選擇顯示對比亮度
選單密碼 (5.9)	使用者密碼 (5.9.1)	N/A	00000	0~99999	使用者密碼
	管理者密碼 (5.9.2)				管理者密碼

主選項	次選項	說明	單位	出廠值	設定值範圍	功能描述
訊號模擬 (6) (離開此選單 後回到正常 模式)	流速模擬 (6.1)	N/A	m/s	0	-10 ~ 10	模擬流速，使系統做出相應的反應。(選單無返回計時)
	流量模擬 (6.2)	N/A	流量單位	0	0~該口徑最大值	模擬流量，使系統做出相應的反應。(選單無返回計時)
	電流輸出模擬 (6.3)	N/A	mA	4mA	3.6~22	僅電流輸出 port 做出反應。(選單無返回計時)
	頻率輸出模擬 (6.4)	N/A	Hz(pulse/秒)	2	2~8000	pulse port 做出相應頻率輸出。(選單無返回計時)
	輸出接點 1 狀態 (6.5)	N/A	N/A	OFF	ON/OFF	測試接點是否正常。(選單無返回計時)
	輸出接點 2 狀態 (6.6)	N/A	N/A	OFF	ON/OFF	測試接點是否正常。(選單無返回計時)
	輸入訊號 1 狀態 (6.7)	N/A	N/A	Actual	ON/OFF	測試接點是否正常。(選單無返回計時)
	電流輸入狀態 (6.8)	N/A	N/A	Actual	0~24mA	顯示目前輸入電流值。(選單無返回計時)
系統紀錄 (7)	日期設定 (7.1)	N/A	N/A	actual	年：17~99, 月：01~12, 日：01~31	設定日期
	時間設定 (7.2)	N/A	N/A	actual	時：00~23, 分：00~59, 秒：00~59	設定時間
	系統清除 (7.3)	N/A	N/A	取消	取消, 確認	清除全部紀錄
	系統紀錄資訊 (7.4)	N/A	N/A	actual	N/A	檢視記錄資訊
產品資訊 (8)	韌體版本 (8.1)			actual		

※選項 1.3、1.9、2.2、2.5、2.6、5.6、5.9、7.3, 只有管理者權限可作更改

14.3 各參數設定範圍說明

顯示畫面說明

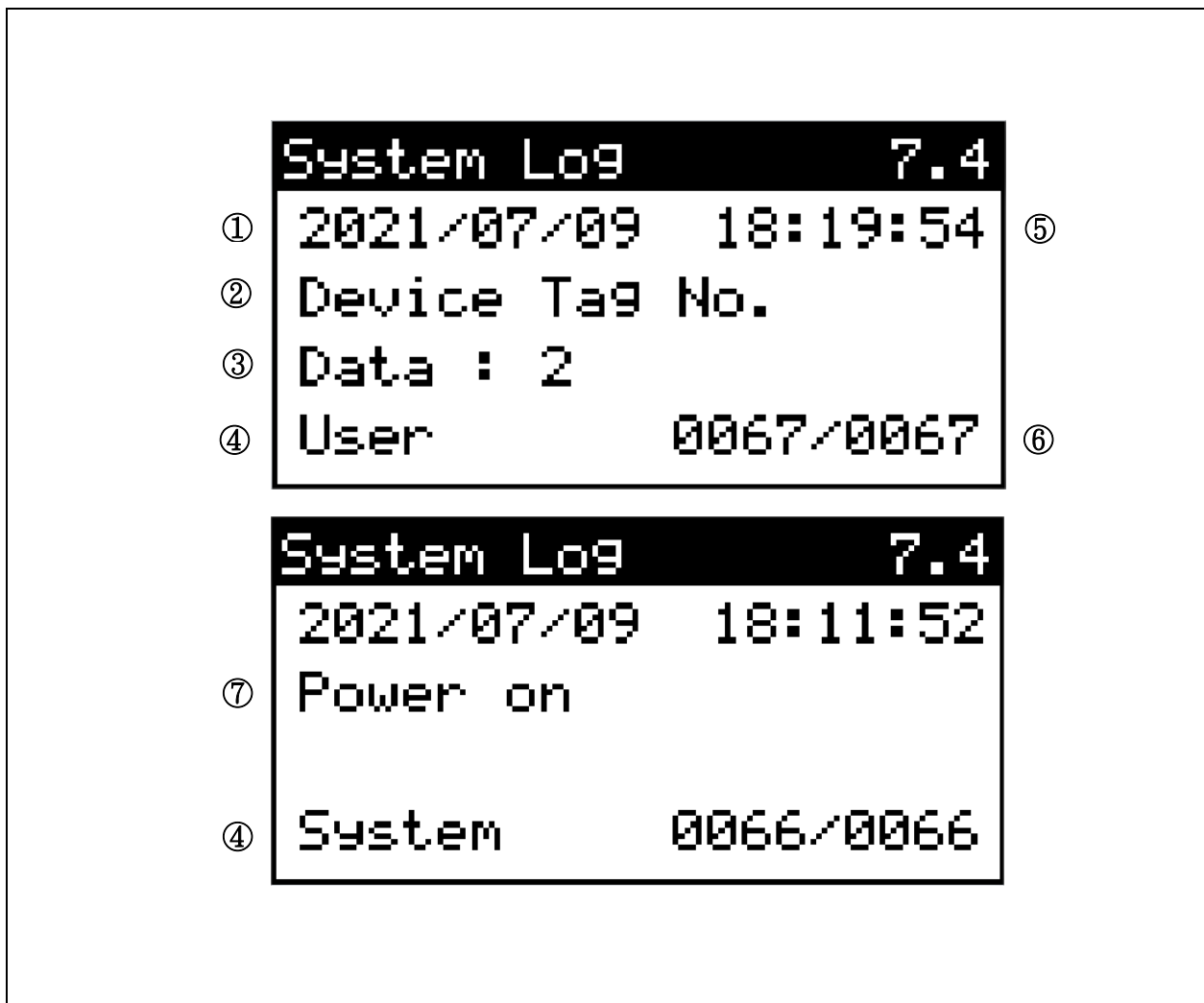

項次	欄位說明
1	事件發生日期。
2	被修改參數名稱，修改者為『User』、『Admin』
3	被修改參數內容
4	修改參數的操作者，區分為『User』、『Admin』、『System』
5	事件發生時間
6	目前總紀錄筆數
7	系統事件發生名稱，修改者為『System』，詳見下表。

分類	訊息	說明
系統硬體狀態	系統開機	系統開機時紀錄當下時間
	系統關機	系統關機時紀錄當下時間
使用者設定	總量重置設定	允許操作者為 Admin
	流量係數 K	允許操作者為 Admin
	流量計口徑	允許操作者為 Admin
	管理者密碼	允許操作者為 Admin
	使用者密碼	允許操作者為 User/Admin
	恢復出廠設定值	允許操作者為 Admin
	其它操作介面參數	權限分級詳見參數設定功能說明 14.2

15. 產品選型

型號	訂購料號
EPD36	EPD10300-A

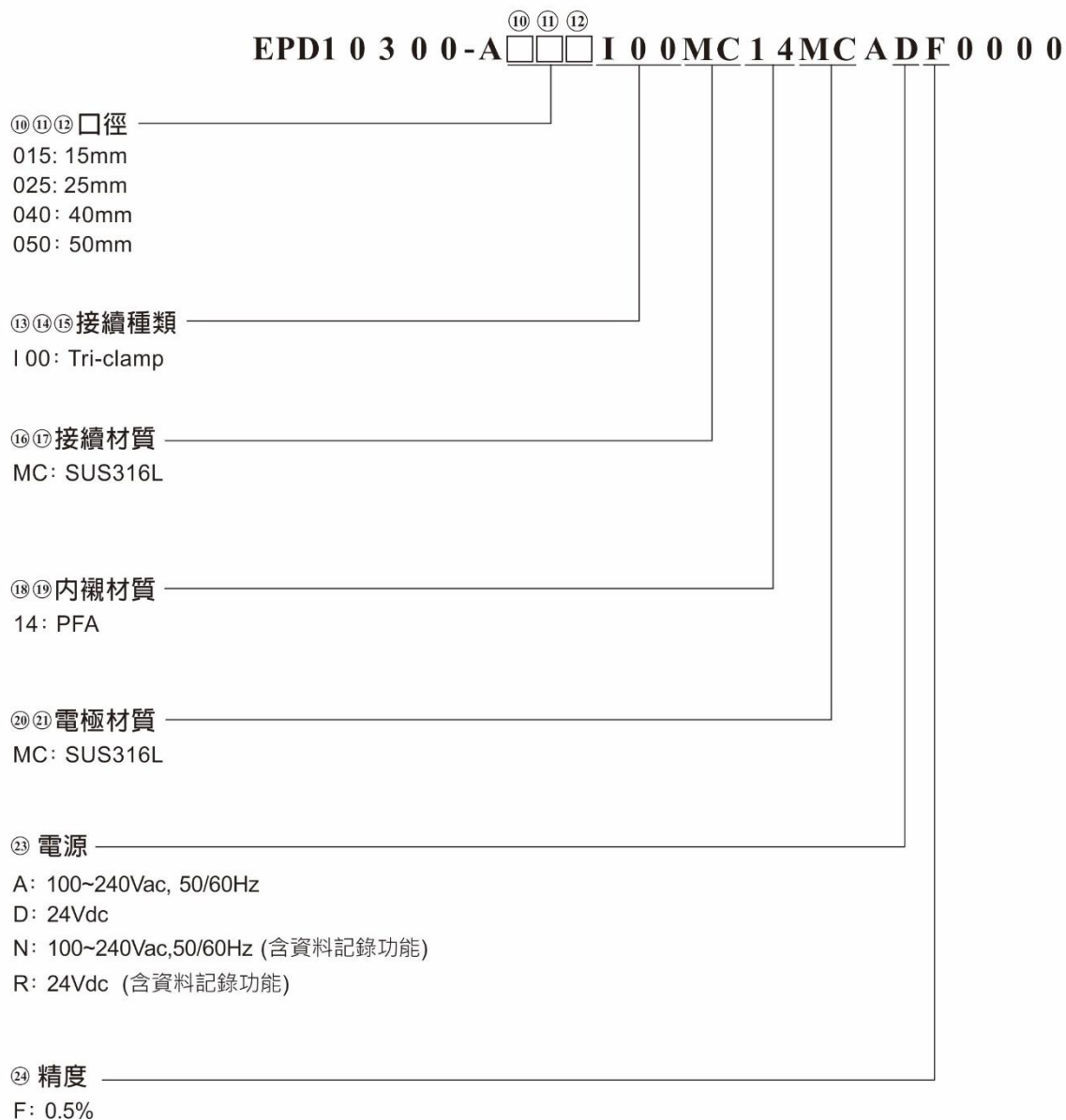

16. 運輸與貯存

為防止流量計在轉運時受到損傷，在到達安裝現場以前，請保持製造廠發運時的包裝狀態。在貯存過程中，貯存地點應具備下列條件：

- 需做適當防雨及防潮
- 盡可能的減少運送時的振動並避免撞擊
- 溫度範圍-20~70℃
- 溼度低於 80%
- 貯存使用過的感測器，須先清除附著於襯裏和電極表面上的被測介質，避免長期暴露在空氣中而氧化
- 露天貯存，流量計性能可能會受影響

17. 故障檢查與維修

如果流量計出現故障與無法達到精度要求，請嘗試利用下表說明進行排除

現象	檢查	處理方法
無法達到精度	<ul style="list-style-type: none"> ■ 流量計零點是否漂移 	<ul style="list-style-type: none"> ■ 進行零點校正。請參閱選單，要做到飽管且水不流動方可執行。
	<ul style="list-style-type: none"> ■ 管道是否充滿液體 	<ul style="list-style-type: none"> ■ 改變安裝位置，使流體充滿管道
	<ul style="list-style-type: none"> ■ 流量計是否在接近流率範圍上限或下限值工作 	<ul style="list-style-type: none"> ■ 降低或提高流速，使流速介於 1m/s ~10m/s 之間
	<ul style="list-style-type: none"> ■ 檢查量程設定是否正確 	<ul style="list-style-type: none"> ■ 確保流量計量程和接收流量計訊號設備設定義的量程是一致的
	<ul style="list-style-type: none"> ■ 檢查流量計輸出連接是否正確 	<ul style="list-style-type: none"> ■ 重新連接，並確保線路通暢
	<ul style="list-style-type: none"> ■ 流量計與管路之間接地是否良好 	<ul style="list-style-type: none"> ■ 將流量計正確接地，接地阻接不得高於 10Ω
	<ul style="list-style-type: none"> ■ 檢查傳送器的感測器 K 系數值與感測器銘牌上標示是否一致 	<ul style="list-style-type: none"> ■ K 系數值可能被第三人調整過，請調回
開機無畫面	<ul style="list-style-type: none"> ■ 檢查流量計電源、開關、保險絲等供電設施是否正常 	<ul style="list-style-type: none"> ■ 排除異常，使流量計可以正確取得電源 ■ 流量計可能損壞，聯繫原廠銷售。
無法進行通訊	<ul style="list-style-type: none"> ■ 檢查 RS-485 通訊功能 	<ul style="list-style-type: none"> ■ 確認 RS-485 轉換器是否能正常工作。 ■ 各項 RS-485 位元格式/ID/鮑率參數查核正確
無脈波輸出	<ul style="list-style-type: none"> ■ 檢查是否有額外供電 12VDC 給輸出端 	<ul style="list-style-type: none"> ■ 出廠值為無源 NPN 輸出，需外接電源
顯示值亂跳不穩定	<ul style="list-style-type: none"> ■ 管道液體導電率不高 	<ul style="list-style-type: none"> ■ 檢查比對管道液體材料特性
	<ul style="list-style-type: none"> ■ 接地環未附帶或是連接不良 	<ul style="list-style-type: none"> ■ 檢查訂單明細，無論管道材質都須有接地環；針對接地接線請詳細閱讀操作說明書使用方法
	<ul style="list-style-type: none"> ■ 流量計安裝於馬達高壓干擾區域 	<ul style="list-style-type: none"> ■ 訊號線或電源請重新拉線遠離干擾區域
	<ul style="list-style-type: none"> ■ 空管水氣潮濕干擾 	<ul style="list-style-type: none"> ■ 開啟空管警報
	<ul style="list-style-type: none"> ■ 流量計電源火線對地有漏電壓流 	<ul style="list-style-type: none"> ■ 重新拉電源線，流量計重置回原廠值，依流量計管道尺寸與 K 值等等參數重新設定
	<ul style="list-style-type: none"> ■ 轉換器或主機電路板故障 	<ul style="list-style-type: none"> ■ 備品電路板更新或與原廠聯繫處理

管道有流量但顯示沒有流量值	<ul style="list-style-type: none"> 低流量屏蔽值是否大於現在流量 	<ul style="list-style-type: none"> 修正並降低數值(參考出廠值)
	<ul style="list-style-type: none"> 分離型流量計的信號線與勵磁線是否正常 	<ul style="list-style-type: none"> 查看傳感器與傳送器兩邊端子台線路正確與鎖緊
	<ul style="list-style-type: none"> 流量計感測器箭頭方向與管道水流一致嗎 	<ul style="list-style-type: none"> 檢查感測器方向正確並且在參數流體方向亦要正確
	<ul style="list-style-type: none"> 管道流體是否是否有充滿測量管 	<ul style="list-style-type: none"> 感測器最好安裝在水平管路下凹處或管後有爬升段確保飽管
螢幕顯示異常訊息	<ul style="list-style-type: none"> 查詢操作手冊異常訊息顯示 	<ul style="list-style-type: none"> 詳見異常訊息顯示說明，適當排查。
流量計本體內襯凸起	<ul style="list-style-type: none"> 管道是否因負壓產生 	<ul style="list-style-type: none"> 負壓的問題能否移除，不行的話，須改用其他產品。
4-20mA 輸出不正常	<ul style="list-style-type: none"> 無電流輸出 	<ul style="list-style-type: none"> 移除原有線路，使用手持電錶檢測，確認產品功能 恢復出廠預設值後重新測試。 聯繫當地技術人員進行異常排除。
流量誤差大	<ul style="list-style-type: none"> 濾波設定參數是否錯誤 	<ul style="list-style-type: none"> 減少訊號平均時間並關閉中位數濾波功能。
	<ul style="list-style-type: none"> 內襯與電極是否覆蓋附著物 	<ul style="list-style-type: none"> 檢查或清潔電極覆蓋的附著物。
	<ul style="list-style-type: none"> 排除上述兩點問題 	<ul style="list-style-type: none"> 聯繫當地技術人員進行異常排除。

錯誤代碼說明

警示狀態	說明
Empty Tube	量測管內沒有液體或液體導電度低於 5us/cm
Sensor Discon.	傳感器未正確連接或勵磁電流異常，無法正常檢知流量。
Electrode Coating	電極嚴重被覆蓋非導電性物質。
Init. Comm. Err.	內部功能異常。(請嘗試重開機)

18. MODBUS 通訊協定

EPD36 Measuring System ModBus Communication Address (Auto ID)List

位置 (十六進制)	位置 (十進制)	變數名稱	資料類型	單位	範圍	定義	權限
0x1000	4096	gt_modbus_slave_fine_tek_id[0]	UINT8	N/A		"F"	Read only(Header)
0x1001	4097	gt_modbus_slave_fine_tek_id[2]	UINT8	N/A		"NE"	Read only(Header)
0x1002	4098	gt_modbus_slave_fine_tek_id[4]	UINT8	N/A		"-T"	Read only(Header)
0x1003	4099	gt_modbus_slave_fine_tek_id[6]	UINT8	N/A		"EK"	Read only(Header)
0x1004	4100	PFC_PRODUCT_TYPE	UINT16	N/A		"FM"	Read only(Header)
0x1005	4101	PFC_PRODUCT_NUMBER	UINT16	N/A		0x0001	Read only(Header)
0x1006	4102	PFC_PRODUCT_VERSION	UINT16	N/A		0x0001	Read only(Header)

0x1010 量測狀態

位置 (十六進制)	位置 (十進制)	變數名稱	資料類型	單位	範圍	定義	權限
0x1010	4112	PFC_FlowTotal_FRAM_FWD_VAL-High	FLOAT64	m ³		目前總順向 累積流量	Read only
0x1011	4113	PFC_FlowTotal_FRAM_FWD_VAL+1					Read only
0x1012	4114	PFC_FlowTotal_FRAM_FWD_VAL+2					Read only
0x1013	4115	PFC_FlowTotal_FRAM_FWD_VAL-Low					Read only
0x1014	4116	PFC_FlowTotal_FRAM_REV_VAL-High	FLOAT64	m ³		目前總逆向 累積流量	Read only
0x1015	4117	PFC_FlowTotal_FRAM_REV_VAL+1					Read only
0x1016	4118	PFC_FlowTotal_FRAM_REV_VAL+2					Read only

0x1017	4119	PFC_FlowTotal_FRAM_REV_VAL-Low					Read only
0x1018	4120	PFC_FlowTotal_FRAM_BI_DIR_VAL-High	FLOAT64	m ³		目前總雙向累積流量	Read only
0x1019	4121	PFC_FlowTotal_FRAM_BI_DIR_VAL+1					Read only
0x101A	4122	PFC_FlowTotal_FRAM_BI_DIR_VAL+2					Read only
0x101B	4123	PFC_FlowTotal_FRAM_BI_DIR_VAL-Low					Read only
0x101C	4124	PFC_FlowRate_Main_Val-High					FLOAT64
0x101D	4125	PFC_FlowRate_Main_Val+1	Read only				
0x101E	4126	PFC_FlowRate_Main_Val+2	Read only				
0x101F	4127	PFC_FlowRate_Main_Val-Low	Read only				
0x1020	4128	gb_pfc_flowrate_rawdata_m_s-High	FLOAT64	m/s		\系統設定\ 系統資訊\ 目前流速 (真實流速，需能與流量對應)	Read only
0x1021	4129	gb_pfc_flowrate_rawdata_m_s+1					Read only
0x1022	4130	gb_pfc_flowrate_rawdata_m_s+2					Read only
0x1023	4131	gb_pfc_flowrate_rawdata_m_s-Low					Read only
0x1024	4132	gf_pfc_current_out_value-High	FLOAT32	mA		目前輸出電流值	Read only
0x1025	4133	gf_pfc_current_out_value-Low					Read only
0x1026	4134	PFC_SIMULATION_INPUT_CURR-High	FLOAT32	mA		目前輸入電流值	Read only
0x1027	4135	PFC_SIMULATION_INPUT_CURR-Low					Read only
0x1028	4136	gb_pfc_liquid_resistance-High	FLOAT32	KΩ		\系統設定\ 系統資訊\ 液體阻抗值	Read only
0x1029	4137	gb_pfc_liquid_resistance-Low					Read only
0x102A	4138	PFC_FlowTotal_FWD_VAL-Low	UINT32	Liter		目前總順向累積流量	Read only
0x102B	4139	PFC_FlowTotal_FWD_VAL-High					Read only
0x102C	4140	PFC_FlowTotal_REV_VAL-Low	UINT32	Liter		目前總逆向累積流量	Read only

0x102D	4141	PFC_FlowTotal_REV_VAL-High					Read only
0x102E	4142	PFC_FlowTotal_BI_VAL-Low	UINT32	Liter		目前總雙向 累積流量	Read only
0x102F	4143	PFC_FlowTotal_BI_VAL-High					Read only
0x1030	4144	PFC_Flowrate_Main_Vluae-Low	FLOAT32	Rate Unit		目前瞬間流 量顯示值	Read only
0x1031	4145	PFC_Flowrate_Main_Vluae-High					Read only
0x1032	4146	PFC_Flowrate_rawdata_vluae-Low	FLOAT32	m/s		\系統設定\ 系統資訊\ 目前流速 (真實流 速，需能與 流量對應)	Read only
0x1033	4147	PFC_Flowrate_rawdata_vluae-High					Read only

0x1040 系統狀態

位置 (十六進制)	位置 (十進制)	變數名稱	資料類型	單位	範圍	定義	權限
0x1040	4160	PFC_TEMPERATURE_BOARD_NOW-High	FLOAT32	°C		電路板溫度	Read only
0x1041	4161	PFC_TEMPERATURE_BOARD_NOW-Low					Read only
0x1042	4162	PFC_SELF_TEST_TUBE_STATUS	UINT16	N/A	0：正常 1：空管	系統設定\ 系統資訊\ 測量管狀態	Read only
0x1043	4163	pfc_system_status_code_value-High	UINT32	N/A		系統設定\ 系統資訊\ 系統狀態碼	Read only
0x1044	4164	pfc_system_status_code_value-Low					Read only

0x1050 參數設定-系統資訊

位置 (十六進制)	位置 (十進制)	變數名稱	資料類型	單位	範圍	定義	權限
0x1050	4176	PFC_PRODUCT_VERSION	UINT16	N/A		韌體版本 (Master)	Read only

0x1055 參數設定-基礎設定

位置 (十六進制)	位置 (十進制)	變數名稱	資料類型	單位	範圍	定義	權限
0x1055	4181	PFC_BASIC_SET_DEVICE_T AG _NUM	UINT16	N/A	00001~65535 (Default:1)	基礎設定/ 裝置位號	Read /Write
0x1056	4182	PFC_BASIC_SET_MEASURE _TYPE		N/A	0:水 1:none	設定量測液 體種類	Read /Write
0x1057	4183	PFC_BASIC_SET_TUBE_SIZE -High	FLOAT32	10~100 mm	設定管徑除以 1000；例如 DN80 = 80/1000 = 0.08	基礎設定/ 流量計口徑	Read /Write
0x1058	4184	PFC_BASIC_SET_TUBE_SIZE -Low		125~50 0mm			
0x1059	4185	PFC_BASIC_SET_TUBE_SIZE -Low	UINT16	N/A	0:L/m 1:L/h 2:m3/m 3:m3/h 4:gal/m 5:gal/h 6:kg/m 7:kg/h 8:T/m 9:T/h 10:m3/d	基礎設定/ 瞬時流率單 位	Read /Write
0x105A	4186	PFC_BASIC_SET_FLOW_SPA N-High	FLOAT64	m ³ /s	+口徑(m) ² *0.0785 ~ 口徑 (m) ² *7.85	基礎設定/ 流率滿量程	Read /Write
0x105B	4187	PFC_BASIC_SET_FLOW_SPA N+1					Read /Write
0x105C	4188	PFC_BASIC_SET_FLOW_SPA N+2					Read /Write
0x105D	4189	PFC_BASIC_SET_FLOW_SPA N-Low					Read /Write
0x105E	4190	PFC_BASIC_SET_FLOW_DIR	UINT16	N/A	0:順向 1:逆向	基礎設定/ 流體方向	Read /Write
0x105F	4191	PFC_BASIC_SET_FLOW_TOT AL _UNIT	UINT16	N/A	0:Liter 1:gal 2:m3 3:kg 4:Ton	基礎設定/ 總量累積單 位	Read /Write
0x1060	4192	PFC_BASIC_SET_TOTAL_MO DE	UINT16	N/A	0:順向 1:逆向 2:雙向	基礎設定/ 總量累積模 式	Read /Write
0x1061	4193	PFC_BASIC_SET_TOTAL_RE SET	UINT16	N/A	0:取消 1:確認	基礎設定/ 總量重置設 定	Read /Write

0x1070 參數設定-進階設定

位置 (十六進制)	位置 (十進制)	變數名稱	資料類型	單位	範圍	定義	權限
0x1070	4208	PFC_BASIC_SET_ZERO_ADJ -High	FLOAT64	m/s	-0.5000~ +0.5000	基礎設定/ 流量零點調 整	Read /Write
0x1071	4209	PFC_BASIC_SET_ZERO_ADJ +1					Read /Write
0x1072	4210	PFC_BASIC_SET_ZERO_ADJ +2					Read /Write
0x1073	4211	PFC_BASIC_SET_ZERO_ADJ -Low					Read /Write
0x1074	4212	PFC_BASIC_SET_K_FACTOR -High	FLOAT64	N/A	+0.0000~ +3.0000 (Default:1.0)	基礎設定/ 流量係數 K	Read /Write
0x1075	4213	PFC_BASIC_SET_K_FACTOR +1					Read /Write
0x1076	4214	PFC_BASIC_SET_K_FACTOR +2					Read /Write
0x1077	4215	PFC_BASIC_SET_K_FACTOR -Low					Read /Write
0x1078	4216	PFC_ADVANCED_SET_DENS ITY-High	FLOAT64	g/cm ³	+0.0001~ +9.9999 (Default:1.0)	基礎設定/ 密度	Read /Write
0x1079	4217	PFC_ADVANCED_SET_DENS ITY+1					Read /Write
0x107A	4218	PFC_ADVANCED_SET_DENS ITY+2					Read /Write
0x107B	4219	PFC_ADVANCED_SET_DENS ITY-Low					Read /Write
0x107C	4220	PFC_BASIC_SET_LOW_FLO W_CUTOFF-High	FLOAT64	%	+0.0000~+100.0 0 (Default:0.5)	基礎設定/ 低流量屏避	Read /Write
0x107D	4221	PFC_BASIC_SET_LOW_FLO W_CUTOFF+1					Read /Write
0x107E	4222	PFC_BASIC_SET_LOW_FLO W_CUTOFF+2					Read /Write
0x107F	4223	PFC_BASIC_SET_LOW_FLO W_CUTOFF-Low					Read /Write
0x1080	4224	PFC_ADVANCED_SET_FWD_ TOTAL_INIT-High	FLOAT64	m3	0~99999	進階設定/ 順向總量起 始值	Read /Write
0x1081	4225	PFC_ADVANCED_SET_FWD_ TOTAL_INIT+1					Read /Write

0x1082	4226	PFC_ADVANCED_SET_FWD_TOTAL_INIT+2					Read /Write
0x1083	4227	PFC_ADVANCED_SET_FWD_TOTAL_INIT-Low					Read /Write
0x1084	4228	PFC_ADVANCED_SET_REV_TOTAL_INIT-High	FLOAT64	m3	0~99999	進階設定/ 反向總量起 始值	Read /Write
0x1085	4229	PFC_ADVANCED_SET_REV_TOTAL_INIT+1					Read /Write
0x1086	4230	PFC_ADVANCED_SET_REV_TOTAL_INIT+2					Read /Write
0x1087	4231	PFC_ADVANCED_SET_REV_TOTAL_INIT-Low					Read /Write
	4232		UINT16	N/A	0~1	零點自動校正 啟動開關	Read /Write

0x1090 參數設定-輸出入訊號設定

位置 (十六進制)	位置 (十進制)	變數名稱	資料類型	單位	範圍	定義	權限
0x1090	4240	PFC_IO_SIGNAL_SET_DAMPING_TIME	UINT16	Second	000~+100 (Default:3)	輸出入訊號 設定/輸入 訊號平均時 間	Read /Write
0x1091	4241	PFC_IO_SIGNAL_SET_PULSE_OUTPUT_MODE	UINT16	N/A	0:NO 1:NC 2:頻率輸出	輸出入訊號 設定/脈波 輸出模式	Read /Write
0x1092	4242	PFC_IO_SIGNAL_SET_PULSE_OUTPUT_UNIT-High	FLOAT64	Liter	+0.0010~ +99.999 (Default:0.01)	輸出入訊號 設定/脈波 單位設定	Read /Write
0x1093	4243	PFC_IO_SIGNAL_SET_PULSE_OUTPUT_UNIT+1					Read /Write
0x1094	4244	PFC_IO_SIGNAL_SET_PULSE_OUTPUT_UNIT+2					Read /Write
0x1095	4245	PFC_IO_SIGNAL_SET_PULSE_OUTPUT_UNIT-Low					Read /Write
0x1096	4246	PFC_IO_SIGNAL_SET_MAX_FREQ-High	FLOAT64	Hz	+0.0010~10.000 (Default:2.0)	輸出入訊號 設定/頻率 設定	Read /Write
0x1097	4247						Read /Write
0x1098	4248						Read /Write
0x1099	4249	PFC_IO_SIGNAL_SET_MAX_FREQ-Low					Read /Write
0x109A	4250	PFC_IO_SIGNAL_SET_OUTPUT_CURR_MODE	UINT16	mA	0: 4-20mA 1: 0-20mA	輸出入訊號 設定/電流 輸出模式設 定	Read /Write

0x109B	4251	PFC_IO_SIGNAL_SET_4MA_FINE_TUNE	INT16	Count	-000.0~ +5000.0 (Default:0)	輸出入訊號 設定/電流 輸出 4mA 微調	Read /Write
0x109C	4252	PFC_IO_SIGNAL_SET_20MA_FINE_TUNE	INT16	Count	-000.0~ +5000.0 (Default:0)	輸出入訊號 設定/電流 輸出 20mA 微調	Read /Write
0x109D	4253	PFC_IO_SIGNAL_SET_DIGIT AL_1_IN_FUNC	UINT16	N/A	0:無 1:總量重置設定	輸出入訊號 設定/輸入 1 接點功能	Read /Write
0x109E	4254	PFC_IO_SIGNAL_SET_DIGIT AL_1_IN_TYPE	UINT16	N/A	0:NO 1:NC	輸出入訊號 設定/輸入 1 接點形式	Read /Write

0x10A5 參數設定-警報設定

位置 (十六進制)	位置 (十進制)	變數名稱	資料類型	單位	範圍	定義	權限
0x10A5	4261	PFC_ALARM_SET_MAX_FLOW_RATE-High	FLOAT64	m ³ /s	+0.0000 ~ 口徑 (m) ² *7.85	警報設定/ 流率上限	Read /Write
0x10A6	4262	PFC_ALARM_SET_MAX_FLOW_RATE+1					Read /Write
0x10A7	4263	PFC_ALARM_SET_MAX_FLOW_RATE+2					Read /Write
0x10A8	4264	PFC_ALARM_SET_MAX_FLOW_RATE-Low					Read /Write
0x10A9	4265	PFC_ALARM_SET_MIN_FLOW_RATE-High	FLOAT64	m ³ /s	+0.0000 ~ 口徑 (m) ² *7.85	警報設定/ 流率下限	Read /Write
0x10AA	4266	PFC_ALARM_SET_MIN_FLOW_RATE+1					Read /Write
0x10AB	4267	PFC_ALARM_SET_MIN_FLOW_RATE+2					Read /Write
0x10AC	4268	PFC_ALARM_SET_MIN_FLOW_RATE-Low					Read /Write
0x10AD	4269	PFC_ALARM_SET_EMPTY_TUBE_DETECT	UINT16	N/A	0:關閉 1:啟動	警報設定/ 空管檢測	Read /Write
0x10AE	4270	PFC_ALARM_SET_ALARM_1_FUNC	UINT16	N/A	0:無 1:流量上限 2:流量下限 3:空管警報 4:系統異常	警報設定/ 輸出 1 功能	Read /Write
0x10AF	4271	PFC_ALARM_SET_ALARM_1_TYPE	UINT16	N/A	0:NO 1:NC	警報設定/ 輸出 1 接點 型式	Read /Write
0x10B0	4272	PFC_ALARM_SET_ALARM_2_FUNC	UINT16	N/A	0:無 1:流量上限 2:流量下限 3:空管警報 4:系統異常	警報設定/ 輸出 2 功能	Read /Write
0x10B1	4273	PFC_ALARM_SET_ALARM_2_TYPE	UINT16	N/A	0:NO 1:NC	警報設定/ 輸出 2 接點 型式	Read /Write

0x10B2	4274	PFC_ALARM_SET_CURR_FUNC	UINT16	N/A	0:無 1:空管警報 2:系統異常	警報設定/ 警報電流功能	Read /Write
0x10B3	4275	PFC_ALARM_SET_ALARM_CURR_VAL	UINT16	mA	0:3.6 1:3.8 2:20.5 3:22	警報設定/ 警報電流設定	Read /Write

0x10B9 參數設定-系統設定

位置 (十六進制)	位置 (十進制)	變數名稱	資料類型	單位	範圍	定義	權限
0x10B9	4281	PFC_SYSTEM_SET_LANGUAGE	UINT16	N/A	0:英文 1:繁中 2:簡中	系統設定/ 系統語言	Read /Write
0x10BA	4282	PFC_SYSTEM_SET_ANALOGY_INPUT_4MA_INFO-High	FLOAT32	N/A	0~9999	系統設定/ 類比輸入設定/ 4mA顯示值	Read /Write
0x10BB	4283	PFC_SYSTEM_SET_ANALOGY_INPUT_4MA_INFO-Low					
0x10BC	4284	PFC_SYSTEM_SET_ANALOGY_INPUT_20MA_INFO-High	FLOAT32	N/A	0~9999	系統設定/ 類比輸入設定/ 20mA顯示值	Read /Write
0x10BD	4285	PFC_SYSTEM_SET_ANALOGY_INPUT_20MA_INFO-Low					
0x10BE	4286	PFC_SYSTEM_SET_ANALOGY_INPUT_4_20MA_UNIT	UINT16	N/A	0:None 1:Kpa 2:Mpa 3:Psi 4:Bar 5:°C 6:°F	系統設定/ 類比輸入設定/ 4-20mA輸入單位	Read /Write
0x10BF	4287	PFC_SYSTEM_SET_ANALOGY_INPUT_DOT	UINT16	N/A	0~3	系統設定/ 類比輸入設定/ 顯示小數點位數	Read /Write
0x10C0	4288	PFC_IO_SIGNAL_SET_MODBUS_COMM_ID	UINT16	N/A	0 ~ 255	系統設定/ MODBUS通訊 /Modbus ID	Read /Write

0x10C1	4289	PFC_IO_SIGNAL_SET_MODBUS_COMM_BAUDRATE-High	UINT32	BPS	1200 :1200bps 2400 :2400bps 4800 :4800bps 9600 :9600bps 19200 :19200bps 38400 :38400bps 57600 :57600bps	系統設定 /MODBUS 通訊 /BaudRate	Read /Write
0x10C2	4290	PFC_IO_SIGNAL_SET_MODBUS_COMM_BAUDRATE-Low					
0x10C3	4291	PFC_IO_SIGNAL_SET_MODBUS_COMM_DATA_BITIS	UINT16	N/A	0x0000:8 0x1000:9	系統設定 /MODBUS 通訊/Data bit	Read /Write
0x10C4	4292	PFC_IO_SIGNAL_SET_MODBUS_COMM_STOP_BITS	UINT16	N/A	0x0000:1 0x2000:2	系統設定 /MODBUS 通訊/Stop bit	Read /Write
0x10C5	4293	PFC_IO_SIGNAL_SET_MODBUS_COMM_PARITY	UINT16	N/A	0x0000:無 0x0400:偶同位 0x0600:奇同位	系統設定 /MODBUS 通訊/Parity	Read /Write
0x10C6	4294	PFC_LOAD_DEFAULT_SETTING	UINT16		0 : 取消 1 : 確認	系統設定/ 恢復出廠設 定值	Read /Write

x10C9 參數設定-訊號模擬

位置 (十六進制)	位置 (十進制)	變數名稱	資料類型	單位	範圍	定義	權限
0x10C9	4297	PFC_SIMULATION_FUNC_STATE	UINT16	N/A	0:None 1:流速模擬 2:流量模擬 3:電流輸出模擬 4:頻率輸出模擬 5:輸出接點 1 狀態模擬 6:輸出接點 2 狀態模擬	訊號模擬功能選擇	Read /Write
0x10CA	4298	PFC_SIMULATION_FLOW_SPEED-High	FLOAT64	m/s	-10.000~10.000	訊號模擬/ 流速模擬	Read /Write
0x10CB	4299	PFC_SIMULATION_FLOW_SPEED+1					Read /Write
0x10CC	4300	PFC_SIMULATION_FLOW_SPEED+2					Read /Write

0x10CD	4301	PFC_SIMULATION_FLOW_SPEED-Low					Read /Write
0x10CE	4302	PFC_SIMULATION_FLOW_RATE-High	FLOAT64	Rate Unit	+0.0000 ~ 口徑 (m)^2 *7.85	訊號模擬/ 流量模擬	Read /Write
0x10CF	4303	PFC_SIMULATION_FLOW_RATE+1					Read /Write
0x10D0	4304	PFC_SIMULATION_FLOW_RATE+2					Read /Write
0x10D1	4305	PFC_SIMULATION_FLOW_RATE-Low					Read /Write
0x10D2	4306	PFC_SIMULATION_OUTPUT_CURR-High	FLOAT32	mA	3.6~22	訊號模擬/ 電流輸出模擬	Read /Write
0x10D3	4307	PFC_SIMULATION_OUTPUT_CURR-Low					Read /Write
0x10D4	4308	PFC_SIMULATION_OUTPUT_FREQ	UINT16	Khz	2~8Khz	訊號模擬/ 頻率輸出模擬	Read /Write
0x10D5	4309	PFC_SIMULATION_OUTPUT_1_STATUS	UINT16	N/A	0: OPEN 1: CLOSED	訊號模擬/ 輸出接點 1 狀態模擬	Read /Write
0x10D6	4310	PFC_SIMULATION_OUTPUT_2_STATUS	UINT16	N/A	0: OPEN 1: CLOSED	訊號模擬/ 輸出接點 2 狀態模擬	Read /Write

0x10DE 系統特殊設定

位置 (十六進制)	位置 (十進制)	變數名稱	資料類型	單位	範圍	定義	權限
0x10DE	4318	PFC_SAVE_SYSTEM_VARIABLE_EEPROM	UINT16	N/A	0: 無 1: 寫入	寫入 USER EEPROM	Read /Write
0x10DF	4319	PFC_ENG_MODE_SAVE_SETTING	UINT16	N/A	0: 無 1: 寫入	寫入 FACTORY 設定 EEPROM	Read /Write
0x10E0	4320	pfc_auto_set_excitation_frequency_flag	UINT16	N/A	0: 無 1: 啟動	自動依據頻率與管徑設定激磁頻率	Read /Write