

# EG50 Magnetostrictive Level Transmitter

## Operation Manual

### INSTALLATION

- Sensor can be directly top mounted if the size of the connection hole is bigger than the diameter of the float.
- In case the diameter of the float is bigger than connection size, firstly dismantle float and mount. While installing back the float needs to be the right direction. Float have a mark showing correct direction to be mounted
- Position of the ring clip must be aligned with stem marked position
- Sensor must not be mishandled, squeezed, bended or deformed. In case of any deformation and abnormal functioning, sensor needs to be sent back to factory for repair & calibration
- Please do not replace the specifications of the float without permission; otherwise, the product would fail to function properly.
- The float should be prevented from striking or dropping on the ground so as to avoid breaking the magnet inside the float and losing its function.
- Please do not open the junction box to ensure accuracy of the measurement.
- During transportation, sensor must be covered with anti vibration packaging such as bubble packaging or spongy packaging etc.
- When sensor is installed on non-metallic tank, the housing should be well grounded.

### INSTALLATION

Measuring range	50~1000mm
Output	4-20mA or 20-4mA RL ≤ 500Ohms
Resolution	≤45um
Linearity	Range of more than 500mm, error ± 0.1% F.S Range of 500mm below the error of ± 500um
Repeatability	≤±0.005% F.S
Digital output	RS485
Power supply	18~30Vdc
Ambient temp.	-40°C ~85°C
Operation temp.	-40°C ~125°C

### DIMENSION

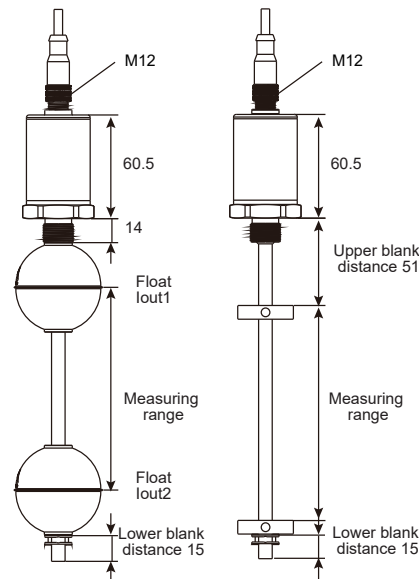

### INSTALLATION METHOD IF THE FLOAT HAS TO BE TAKEN OFF BEFORE INSTALLATION

#### Step 1

Loosen the ring clip at stem end

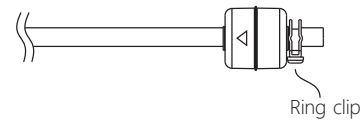

#### Step 2

Take off the float.

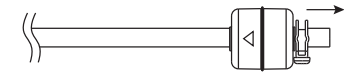

#### Step 3

Install the product itself into the tank, and screw the connection well.

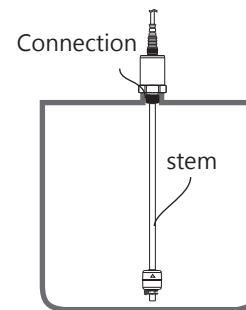

#### Step 4

Put back the float onto the stem by specific direction mark on the float has to be toward the housing

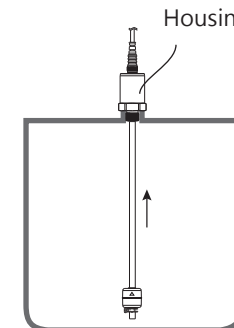

#### Step 5

Screw the ring clip well on the stem

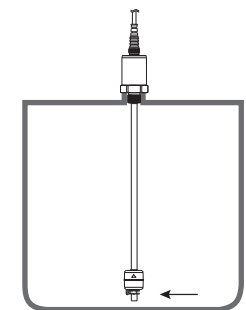

### WIRING DESCRIPTION

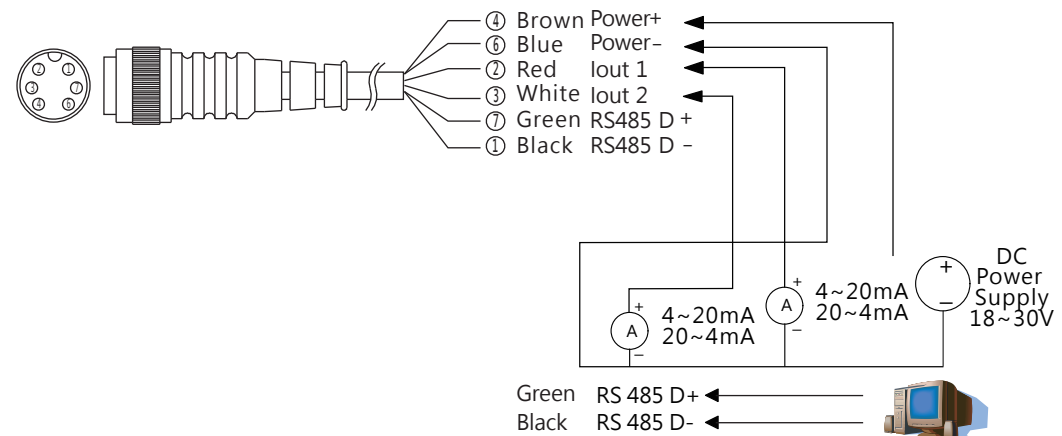

## MODBUS TABLE LIST

Item	Definition	Address(Hex)	Address(Dec)	Data type	Data quantity	Unit / Number	Authority
1	FineTek ID	0x1000	4096	STRING	1	436832	Read Olly
2	Model	0x1004	4100	UINT16	1	EG	Read Olly
3	Product Number	0x1005	4101	UINT16	1	0x0005	Read Olly
4	Product Version	0x1006	4102	UINT16	1	0x0001	Read Olly
5	First float distance	0x1007	4103	FLOAT	1	1mm	Read Olly
6	Second float distance	0x100a	4106	FLOAT	1	1mm	Read Olly
7	Measuring range	0x1010	4112	FLOAT	1	1mm	Read Olly
8	First float value(%)	0x1026	4134	FLOAT	1	%	Read Olly
9	Second float value(%)	0x1028	4136	FLOAT	1	%	Read Olly
10	Temperature	0x102a	4138	FLOAT	1	°C	Read / Write
11	Modbus ID	0x102c	4140	UINT16	1	1(Default)	Read / Write
12	Baud rate	0x102d	4141	UINT16	1	9600(Default)	Read / Write
13	First Float up Limit (20mA)	0x1034	4148	FLOAT	1	1mm	Read / Write
14	First Float down Limit (4mA)	0x1036	4150	FLOAT	1	1mm	Read / Write
15	Save for memory of system	0x1054	4180	UINT16	1	Default value:0 Set value of 1 for saving	Read / Write
16	Save for Calibration	0x1057	4183	UINT16	1	Default value:0 Set value of 1 for saving	Read / Write

## TROUBLE SHOOTING

Trouble	Possible cause	Solution
No signal	Wiring error	Make sure the connection is correct
Un-Normal Signal	Wrong direction of float	Confirm the direction of the float installation
	The inner magnet of the float breaks	Replace the float
	Possible cause	Make sure the pole is not bent
	Housing isn't well grounded to cause signal interference.	Kindly check if it's well grounded
Float Doesn't Work	The float leaks	Replace the float
Disable to connect by RS485	Incorrect wiring method	Checking the wiring diagram to ensure

## WARRANTY

### New Product Warranty

Our product warranty period is 12 months from the date of dispatch. During this period in case of any malfunction, company don't charge for testing, components and repair. In case the product is defected or damaged during transportation, customers are advised to report matter with 7 days.

Company will bear repair charges or replace defected product. While sending back defected products for repair, please send back the complete set without any tearing. Send the defected product using appropriate safety packaging in order to avoid transportation damage.

Warranty will not be covered on the following conditions

1. After expiry of warranty period.
2. Not following operation manual or operation conditions such as using product over operation temperature or pressure etc.
3. Product damage due to nature disaster such as flood, fire, earthquake, lightening, typhoon etc..

There will be a maintenance fee for products that are not covered by the warranty.



**FineTek Co., Ltd.**

No.16, Tzuchiang St., Tucheng Industrial Park, New Taipei City 23678, Taiwan.  
Tel: 886-2-22696789 Fax: 886-2-22686682  
Email: info@fine-tek.com http://www.fine-tek.com



08-EG50-B4-EM,11/06/2024

