

SC24P/N Series Mini Tuning Fork Level Switch

Operation Manual

WIRING

Power supply is DC. Output is PNP / NPN. Please see Figure 1.

►DIN & Cable Wiring

PNP Output:

■ **High(Max.) Mode:** No. 1 pin(Brown) is connected to N-. No.3 pin(Blue) is connected to L+. Output is connected to No. 2 pin(Black), then connected to N-. No. 4 pin(Yellow Green) goes to ground.

■ **Low(Min.) Mode:** number 1 pin(Brown) is connected to N-. No.2 pin(Black) is connected to L+. Output is connected to No. 3 pin(Blue), then connected to N-. No. 4 pin(Yellow Green) goes to ground.

NPN Output:

■ **High(Max.) Mode:** No. 1 pin(Brown) is connected to L+. No.3 pin(Blue) is connected to N-. Output is connected to No. 2 pin(Black), then connected to L+. No. 4 pin(Yellow Green) goes to ground.

■ **Low(Min.) Mode:** No. 1 pin(Brown) is connected to N-. No.3 pin(Blue) is connected to L+. Output is connected to No.2 pin(Black), then connected to L+. No. 4 pin(Yellow Green) goes to ground.

►M12 x 4Pin Wiring

PNP Output

■ **High(Max.) Mode:** No. 1 pin(Brown) is connected to L+. No.3 pin(Blue) is connected to N-. Output is connected to No. 2 pin White(Green), then connected to N-.

■ **Low(Min.) Mode:** number 1 pin(Brown) is connected to L+. No.3 pin(Blue) is connected to N-. Output is connected to No. 4 pin(Black), then connected to N-.

►NPN Output

■ **High(Max.) Mode:** No. 1 pin(Brown) is connected to L+. No.3 pin(Blue) is connected to N-. Output is connected to No. 2 pin White(Green), then connected to L+.

■ **Low(Min.) Mode:** No. 1 pin(Brown) is connected to L+. No.3 pin(Blue) is connected to N-. Output is connected to No. 4 pin(Black), then connected to L+.

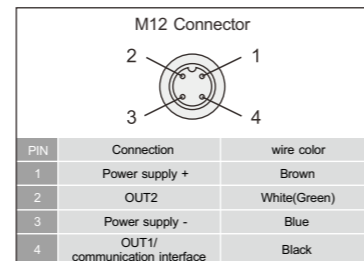
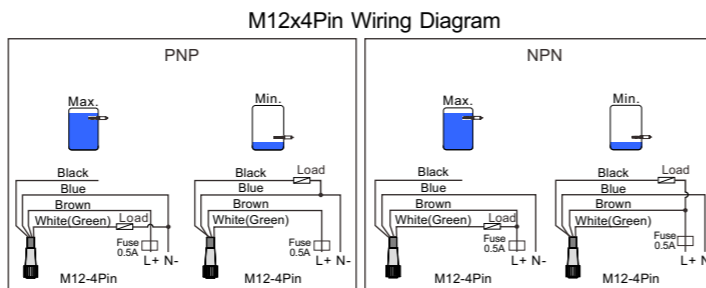
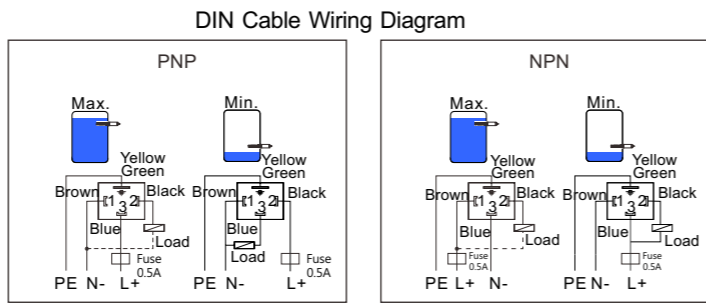
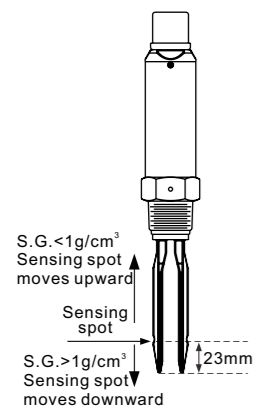

Figure 1 PNP / NPN Output Wiring Diagram

FORK SENSING SPOT



SC24P/N fork sensing spot is shown as Figure 2 below. Considering testing medium is water(S.G.=1 g/cm³), sensing spot is at the fillister about 23mm from the tip. If testing medium has S.G. lower than 1g/cm³, sensing spot would be above the fillister. In contrast, sensing spot will be below the fillister.

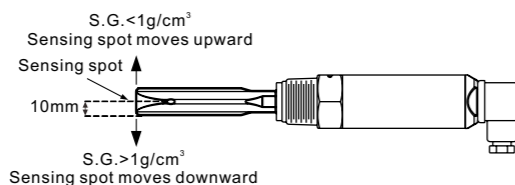

Figure 2 Fork Sensing Spot

MAGNETIC TEST

After the switch is installed and powered, magnetic test function can be performed accordingly please see Figure3. The testing point is marked on the housing label. User holds the magnet and moves it close to testing point, the output status will switch from NO. to NC. or NC to NO. and red LED would switch ON or OFF while fork continues to vibrate. When magnet is pulled away from the testing point, the output status and red LED would return as default while fork continues to vibrate. The purpose of testing is to confirm the wiring and functioning are correct.

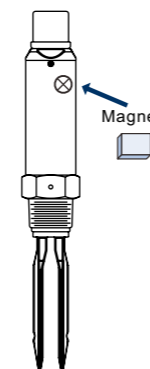

Figure 3 Magnetic Test Diagram

OUTPUT STATUS

SC24P/N When powered with 12~55 Vdc, top of housing would light up with green LED.

►DIN & Cable Type

■ **Low(Min.) Mode:** Tuning fork switch will be actuated 3 seconds after the power is on. Relay is NO and red LED indication is on. When tuning fork is covered by testing medium, vibration stops and relay becomes NC. Red LED indication is off.

■ **High(Max.) Mode:** Tuning fork switch will be actuated 3 seconds after the power is on. Relay is NC and red LED indication is on. When tuning fork is covered by testing medium, vibration stops and relay becomes NO Red LED indication is off.

■ **Flashing red indicates abnormal:** Possible causes overloads or short-circuit load back, equipment malfunction or wear tuning fork probe.

►M12 x 4Pin Type

■ **Low(Min.) Mode:** Tuning fork switch will be actuated 3 seconds after the power is on. Relay is NO and red LED indication is off. When tuning fork is covered by testing medium, vibration stops and relay becomes NC. Red LED indication is on.

■ **High(Max.) Mode:** Tuning fork switch will be actuated 3 seconds after the power is on. Relay is NC and red LED indication is off. When tuning fork is covered by testing medium, vibration stops and relay becomes NO. Red LED indication is on.

■ **Flashing red indicates abnormal:** Possible causes overloads or short-circuit load back, equipment malfunction or wear tuning fork probe.

	Min. Mode		Max. Mode		
Level					Instrument failure
PNP/NPN Output					
Red LED (DIN& Cable)					
Red LED (M12x 4Pin)					

⚡ It represents Blinking

Figure 4 Min./ Max. Mode

INSTALLATION

Horizontal Installation:

- Do not install near substance inlet.

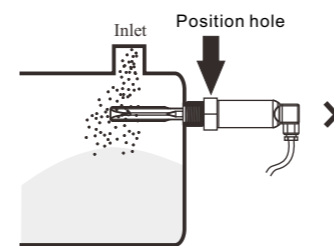

Vertical Installation:

- Opening of the two fork blades is to be as the flow direction.
- Do not install near substance inlet.

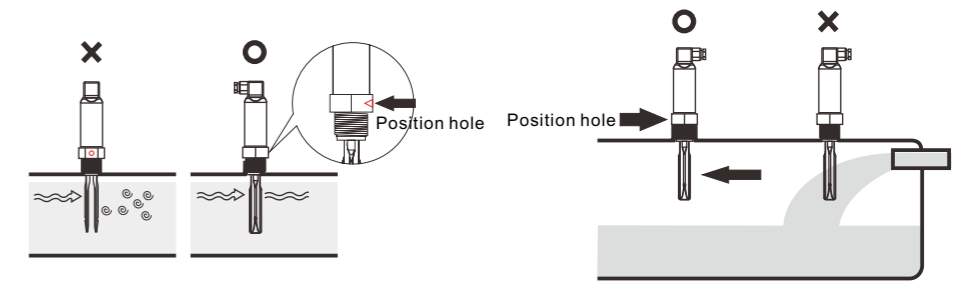

- When installing the product DIN connector wiring down direction, the position hole plug must be upward direction. If not, incorrect installation could be damage the product.

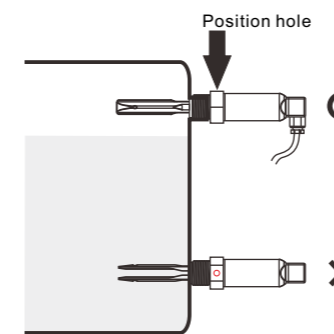

SIMPLE TROUBLESHOOTING

Error	Cause	Solution
Power Supply indicator (Green Light) is off and the switch is not conductive.	No power supply.	Power on or check the wiring and repair.
	Power doesn't meet the specification.	Check the nameplate and power 12~55 Vdc
The signal lamp is normal and the switch output is incorrect.	The control circuit wiring is incorrect.	Check the wiring diagram and correct it.
	The wiring for high/low level is incorrect.	Check the wiring and repair.
Output Indicator (Red Light) is flashing.	The tuning fork is worn, deformed or damaged.	Contact with the local sales representative.
The tuning fork sensed the material, but the switch indicates it does not exist.	Liquid density sensed < 0.7g/cm³, or solid density sensed < 0.07g/cm³, the selected model is not applicable to use.	Contact with the local sales representative.
The tuning fork does not sense the material, but the switch indicates it exists.	The tuning fork is stuck or agglomerated by the material.	Check the tuning fork and remove the sediment.



FineTek Co., Ltd.

No.16, Tzuchiang St., Tucheng Industrial Park, New Taipei City 23678, Taiwan.
Tel: 886-2-22696789 Fax: 886-2-22686682
Email: info@fine-tek.com http://www.fine-tek.com



08-SCX-2A0011-B4-EM,04/24/2023

