

# SC1 SERIES TUNING FORK LEVEL SWITCH OPERATION MANUAL

## Introduction

The tuning fork level switch is a mechanical resonant device which excited by piezoelectric (PZT) elements. When the measured medium comes into contact with the tuning fork, it will change the feedback resonant frequency due to the damping resonances between the exciting PZT and receiving PZT. By detecting the frequency and appropriately tuning the sensitivity of tuning fork level switch on measured material, such device can easily operate for monitoring the alarm level of measured material.

## Feature

1. Providing a universal power supply for operating in voltage range of 20 to 250 (Vac / Vdc).
2. No calibration or complex setting procedure are needed, robust, free of maintenance.
3. High / Low fail safe modes provide user the safety monitoring and real time communication.
4. Equipped with Remote Self-Testing function (RST) to diagnostic the hardware connection with peripherals

## Specification

Item	Specification
Power supply	20~250, 50/60 Hz Vac/Vdc under 18Vac/Vdc, 50/60 Hz, will be fail
Power consumption	Power consumption ≤ 10 VA
Diagnostic frequency	350~370 Hz
Fork length	100 mm Max extension length: 4 m
Ambient temp.	-40~+60°C
Storage temp.	-40~+70°C
Operating temp.	-40~+130°C
Operating humidity	20%~80% RH non-condensed
Operating pressure	-1~600PSI (40BAR)
Act time lag	3 second
Medium density	Solid:density: ≥ 0.07g/cm <sup>3</sup> Liquid:density: ≥ 0.7g/cm <sup>3</sup> Viscosity: 1~10000 cSt
Time delay	0.6 s since the measured material contacted 1-3 s react to the measured material fall off
Output	Relay, SPDT, 3A/250Vac Max.
Input	Remote-test
Status	Green light: indicate power supply Red light: indicate operating mode
Fail-safe	Hi/ Low
Electrical safety	Over Voltage category III
Housing	Aluminum (ADC-12)
Probe	316L/316/304
Enclosure rating	IP65
Mounting	1"PT(standard)or PF thread Flange 1"~6" JIS/DIN/ANSI standard or special specification
Conduit	1/2"NPTX2

## Dimensions

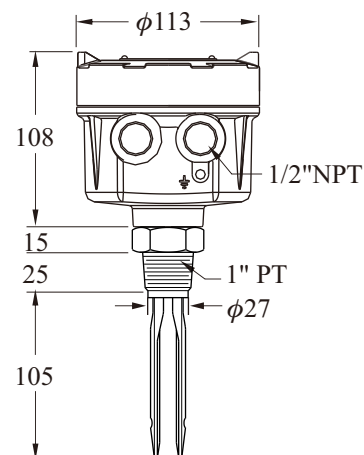

## Terminals Arrangement :

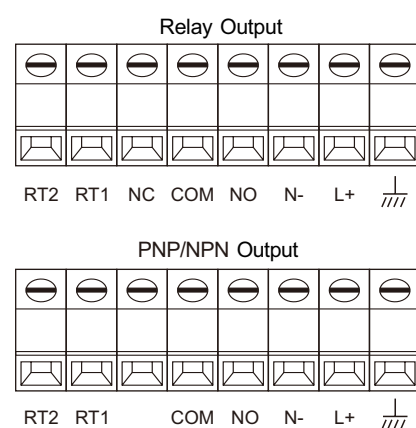
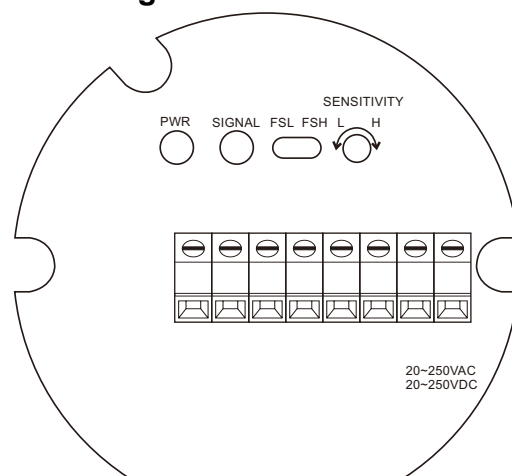

Fig-1. SPDT contact output model

## Terminal Description

- L+, -: Power Supply
- NC, COM, NO: Relay Output
- RT1, RT2: Remote Test
- $\perp$  : Ground Connection
- COM, NO: PNP/NPN Output

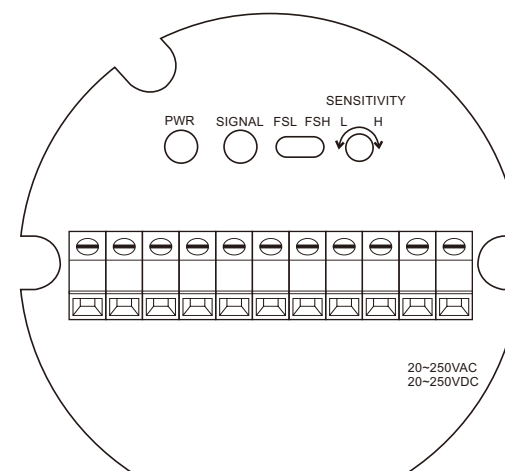

Fig-2. DPDT contact output model

## Terminal Function

- L+, N-: Power Supply
- NC1, COM1, NO1: Relay Output
- NC2, COM2, NO2: Relay Output
- RT1, RT2: Remote-Test
- $\perp$  : Ground Connection
- COM1, NO1: 1<sup>st</sup> PNP/NPN Output
- COM2, NO2: 2<sup>nd</sup> PNP/NPN Output

Refer to the Fig.1-Fig.2, all the wiring should adopt the 18 AWG standard isolation cable and it is compulsory to keep from the dust in the housing and avoid of electric short. To prevent the water or moisture penetrating into the housing, please rotate the top lid in clockwise direction and make sure it is tightly lock.

## Output Description

1. Make sure provide power supply (L+/N-) in range of 20~250 (Vac or Vdc,50/60Hz) and output relay (Relay or PNP/NPN) before wiring. Detail please see Fig-1 and Fig-2.
2. RT1 and RT2 are the testing points that easy user to verify the situation. When the RT1 and RT2 are in electric short, it means the measured material is in contact with the tuning fork level switch. The Relay or PNP/NPN should be activated. In examining the tuning fork level switch, user will finds it keep excitation.
3. Set OUTPUT MODE to FSH · Please refer to Fig 3 and 4:

## Relay contact output:

- a. When vibrating fork is not contacted with media or the bin is empty, Signal is switched on. Relay N.O and COM are connected.
- b. When vibrating fork is contacted with media, Signal is not switched on. Relay N.C and COM are connected.

## PNP/NPN contact output:

- a. When vibrating fork is not contacted with media or the bin is empty, Signal is switched on. Ourput transistor is connected and output functions.
- b. When vibrating fork is contacted with media, Signal is not switched on. MOSFET transistor is not connected and output doesn't function.

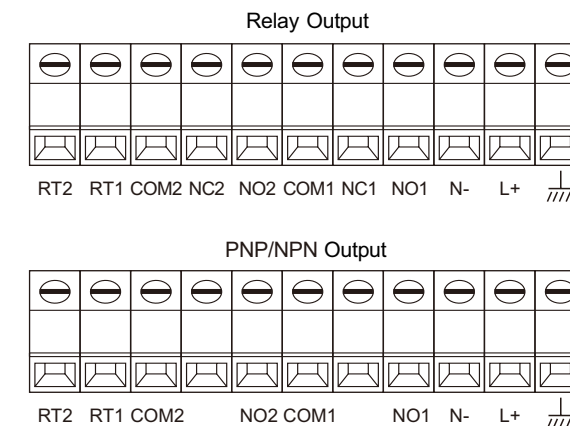

## Panel Function

- PWR: Power Supply (Green Light)
- SIGNAL: Output Indication (Red Light)
- FSH: Power on. The signal LED is on and the relay acts. While the tuning fork level switch contacts with measured material, the signal LED is off and the relay is in not act.
- FSL: Power on. The signal LED is off and the relay is in not act. While the tuning fork level switch contacts with measured material, the signal LED is on and the relay is in act.
- SENSITIVITY L: Low Sensitivity
- SENSITIVITY H: High Sensitivity

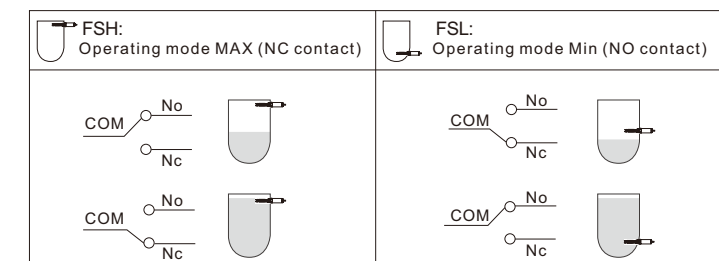

Fig-3. Diagram of Relay contact output

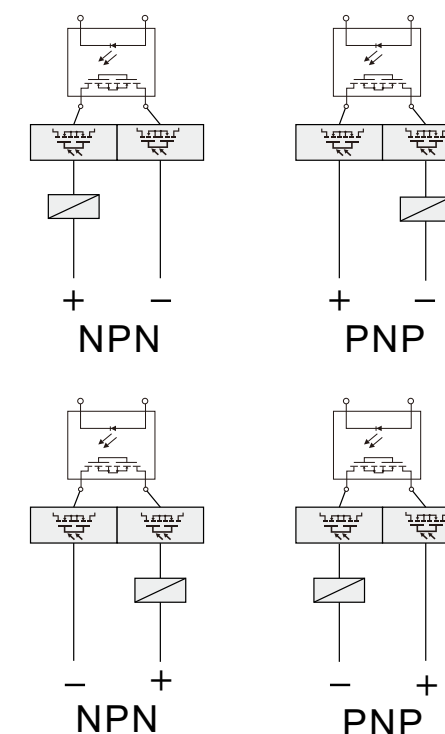

Fig-4. Diagram of PNP/NPN transistor output

4. Adjust OUTPUT MODE to FSL. (Please refer to Fig. 3, 4)

**Relay contact output:**

- a. When vibrating fork is not contacted with media or the bin is empty, Signal is not switched on. Relay N.C and COM are connected.
- B. When vibrating fork is contacted with media, Signal is switched on. Relay N.O and COM are connected.

**PNP/NPN contact output :**

- a. When vibrating fork is not contacted with media or the bin is empty, Signal is not switched on. Output transistor is not connected and output doesn't function.
- b. When vibrating fork is contacted with media, Signal is switched on. Output transistor is connected and output functions.

**FSH (FAIL-SAFE HIGH) PROTECTION:**

On the OUTPUT MODE, select Fail-Safe High Mode (FSH) and install the tuning fork switch at the high position.

**Relay Output:**

**Normal Status:** NO & COM contact of the relay are conducted and the Signal Lamp lights up when tuning fork level switch doesn't sense any materials.  
**Failure:** NC & COM contact of the relay are conducted and the Signal Lamp is out when tuning fork level switch senses the material or when there is power breakdown.

**PNP/NPN Output:**

**Normal Status:** Output is conducted and the Signal Lamp lights up when tuning fork level switch doesn't sense any materials.  
**Failure:** Output is not conducted and the Signal Lamp is out when tuning fork level switch senses the material or when there is power breakdown.

**FSL (FAIL-SAFE LOW) PROTECTION:**

On the OUTPUT MODE, select Fail-Safe Low Mode (FSL) and install the tuning fork switch at the low position.

**Relay Output:**

**Normal Status:** NO & COM contact of the relay are conducted and the Signal Lamp lights up when tuning fork level switch senses the materials.  
**Failure:** NC & COM contact of the relay are conducted and the Signal Lamp is out when tuning fork level switch does not sense the material or when there is power breakdown.  
**PNP/NPN Output:**  
**Normal Status:** Output is conducted and the Signal Lamp lights up when tuning fork level switch senses materials.  
**Failure:** Output is not conducted and the Signal Lamp is out when tuning fork level switch does not sense the material or when there is power breakdown.

**Sensitivity Adjustment/Calibration**

Sensitivity knob located on the right side of the PCB board. It approximately allows 22 turns for sensitivity adjustment. For higher sensitivity need, user please turn the knob clockwise toward H and counterclockwise toward L for lower sensitivity. Factory default is set in high. The physical contact point is located at 15mm from the tip of the fork and it will slightly moving upward or downward along the axis of fork while the sensitivity is changed. For example, the point will move downward for L sensitivity and vice versa. The total range of the physical contact point can be adjusted around 60mm. Roughly for user reference, it will make 30 mm moving of physical contact point while user turn about 10 turns.

Level	FSL		FSH	
Contact Form	NO COM NC	NO COM NC	NO COM NC	NO COM NC
Indication	○	☀	☀	○
Status	Fail	Normal	Normal	Fail

**Installation For Tuning Fork**

**Horizontal Installation:**

1. Can be applied in viscosity, powder, and liquid. Do not install near substance inlet.

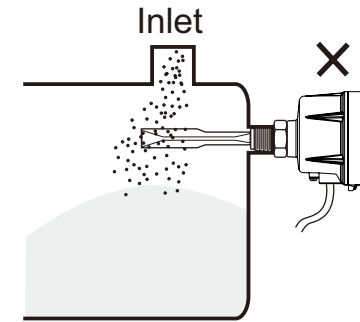

2. Conduit faces downward at installation.

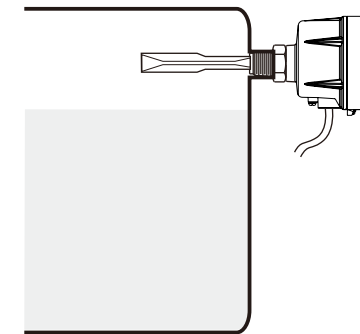

3. To be installed with the surface of two fork blades facing each other horizontally.

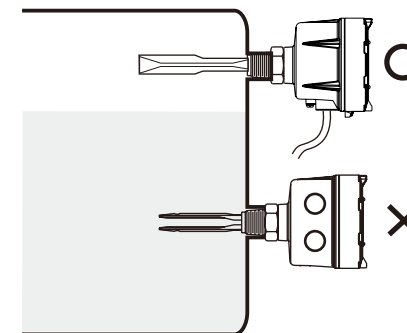

**Vertical Installation:**

1. With high sensitivity, switching point is distanced 15mm away from the tip of fork.

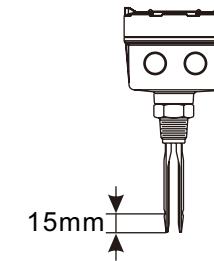

2. Opening of the two fork blades is to be as the flow direction.

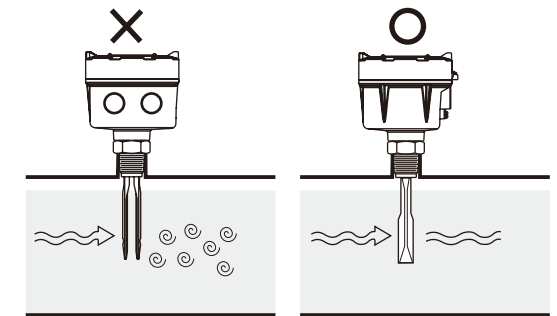

3. Do not install near substance inlet.

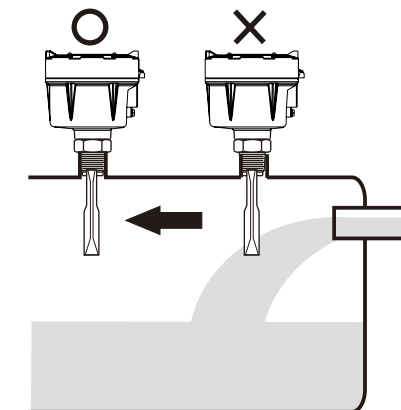

**FineTek Co., Ltd.**

No.16, Tzuchiang St., Tucheng Industrial Park, New Taipei City 23678, Taiwan.  
 Tel: 886-2-22696789 Fax: 886-2-22686682  
 Email: info@fine-tek.com http://www.fine-tek.com



08-SC1XXX-B4-EM, 12/11/2018

